

Catálogo de piezas y equivalencias 10-2018



Somos una empresa con 40 años de trayectoria en el medio, que proveemos todo tipo de juntas para motocicletas, motosierras y motoguadañas sean de fabricación nacional o importadas. Promoviendo la conservación del medio ambiente, hemos desarrollado materiales LIBRE DE ASBESTO (Amianto) que utilizamos en la fabricación de nuestras juntas, con calidad equivalente a los productos originales. Por nuestra capacidad instalada y la alta tecnología de punta, también proveemos juntas para usos industriales en formatos y materiales acorde a especificaciones de los clientes.



La más amplia variedad de Juntas, antiguas y nuevas.

ADLY	GD	MORINI
ALPINO	GHIGGERI	MOTOMEL
APPIA	GILERA	MURAVEY
ATALA	GUERRERO	NANFANG
ATV	GUZZI	NSU
AVANTI	HERCHEE	OKINOI
AX SAP	HERO PUCH	PANTHER
BACCIO	HONDA	PETERSON
BAJAJ	HUSKY	PEUGEOT
BETA	HUSQVARNA	PGO
BLACKSTONE	HYOSUNG	PIAGGIO
BLASTER	IMSA	POLINI
BONNY	ISO	POWER
BONUS	JAWA	PUMITA
BRAVA	JIALING	Q. AX
BRN	JIANSHE	Q. JIAM
CAGIVA AGRALE	JINCHENG	QINGQI
CAHUEL	JUKI	RAFTER
CERRO	KAWASAKI	RIZZATO
CICLON	KAYAK	RPA
CLOVERLY BOLD	KEEWAY	RUMI
CORBIKE	KELLER	SACHS
CORVEN	KINETIC	SAFARI
DA DALT	KIRDI	SALATINO
DAELIM	KONISA	SANYANG
DAYAMA	KTM	SCOUT
DEI	KYMCO	SIAMBRETTA
DEL VISO	LEGNANO	SOMEX
DKW	LH	SUMO
DUCATTI	LIMING	SUNNY
DYNAMIC	MAGISTER	SUZUKI
FENCOR	MAVERICK	TIBO
FENG TONG	MELIPAL	TVS
FRAMBRETTA	METRA	VESPA
FX-TOP	MINKS	YAMAHA
GAMMA	MODENAS	ZADINA
GARELLI	MONDIAL	ZANELLA

INDICE



Descripción	Pág.
Exhibidores	6
Tacos Goma Maza	8
Varios	9
Retenes	10
Tapas y Bases en Cobre	11
Bases en Alma de Metal	11
Tear Off´s	12
Tapas de Válvulas	14
Cubas de Carburador	15
Tapas de Cil. Cuatriciclos	15
Tapas de Cil. Motos	17
Motos y Cuatriciclos	26

INDICE - Motos y Cuatriciclos

Marca	Modelo	Pág.
APPIA	110 ANDINA (Ø54 - CAD.75 MM - P.A.RED.)	38
APPIA	110 CITI PLUS (Ø54-CAD.75 MM - P.A.RED.)	38
APPIA	110 DCN (Ø54 - CAD. 83 MM - P.A.OVAL.)	46
APPIA	110 VECTRA (Ø54 - CAD. 83 MM - P.A.OVAL.)	46
APPIA	125 BERAKA	40
APPIA	125 GEREMY	40
APPIA	125 REGIA (SCOOTER)	28
APPIA	150 BLESS	27
APPIA	150 BREZZA (BAL.)	26
APPIA	150 BREZZA EURO	60
APPIA	150 MONTERO M.08/09	27
APPIA	150 MONTERO M.N. (VAR. BAL.)	26
APPIA	150 MONTERO M.V.	27
APPIA	150 STRONGER	26
APPIA	200 HARDWING	83
APPIA	200 SL	83
ATV	200 WATER COOLER	87
AX SAP	100	91
BAJAJ	100 2T.	91
BAJAJ	125 XCD (STREET)	29
BAJAJ	135 ROUSER	30
BAJAJ	150 NS	32
BAJAJ	150 ROUSER	31
BAJAJ	180 ROUSER	33
BAJAJ	200 AVENGER	34
BAJAJ	200 ROUSER	34
BAJAJ	200 ROUSER NS	35
BAJAJ	220 NAKED	34

Marca	Modelo	Pág.
BAJAJ	220 ROUSER	34
BETA	110 BS (Ø54 - CAD.75 MM - P.A.RED.)	38
BETA	110 URBA (Ø54 - CAD.75 MM - P.A.RED.)	38
BETA	150 BK	47
BETA	200 MOTARD	36
BETA	200 TR CROSS	36
BLACKSTONE	300 MX (4 VALV.)	72
BRAVA	110 ALPINA (Ø54 - CAD.75 MM - P.A.RED.)	38
BRAVA	110 APOLO (Ø54 - CAD.75 MM - P.A.RED.)	38
BRAVA	110 NEVADA (Ø54 - CAD.75 MM - P.A.RED.)	38
BRAVA	125 ATHENE	40
BRAVA	150 ELEKTRA	107
BRAVA	150 WINSTAR	81
BRAVA	200 (VAR. BAL.)	85
CERRO	110 BIX (Ø54 - CAD.75 MM - P.A.RED.)	38
CERRO	110 FLY (Ø54 - CAD.75 MM - P.A.RED.)	38
CERRO	110 LINK (Ø54 - CAD.75 MM - P.A.RED.)	38
CERRO	125 R9	81
CERRO	125 STREET	77
CERRO	150 CE (VAR.)	80
CERRO	150 PRINCE (CAD.)	47
CERRO	150 PRINCE (VAR.)	80
CERRO	150 STREET	107
CERRO	200 COLT (CAD.)	82
CERRO	200 COLT (VAR.)	83
CERRO	200 SCRATCH	83
CERRO	250 (CUATRICICLO)	82
CERRO	250 PRINCE	110



INDICE - Motos y Cuatriciclos

Marca	Modelo	Pág.	Marca	Modelo	Pág.
CORVEN	110 ENERGY (Ø54 - CAD.75 MM - P.A.RED.)	38	GUERRERO	110 GN KEOKEN (Ø54-CAD.75-P.A.RED.)	38
CORVEN	110 MIRAGE (Ø54 - CAD.75 MM - P.A.RED.)	38	GUERRERO	110 GW WARRIOR (Ø54-CAD.75-P.A.RED.)	38
CORVEN	150 HUNTER	107	GUERRERO	110 TRIP (Ø54 - CAD. 83 MM - P.A.OVAL.)	46
CORVEN	150 TRIAX	107	GUERRERO	110 TRIP (Ø54 - CAD.75 MM - P.A.RED.)	38
CORVEN	200 MOTARD (VAR. BAL.)	85	GUERRERO	110 TRIP (Ø54 - CAD.83 MM - P.A.RED.)	39
CORVEN	250 TOURING	50	GUERRERO	125 GC	58
CORVEN	256 INDIANA	110	GUERRERO	150 GMX (CUSTOM)	47
DA-DALT	100 2T.	91	GUERRERO	150 KRYON	81
DA-DALT	110 DS (Ø54 - CAD.75 MM - P.A.RED.)	38	GUERRERO	200 GMX MOTARD (BAL.)	49
DAYAMA	250 PARRILLERA	109	GUERRERO	200 GR1 - GR5	48
DAYAMA	200 DINO	37	GUERRERO	200 TUNDRA (BAL.)	49
DYNAMIC	250 TERRA II	109	GUERRERO	200 TUNDRA (CAD.)	82
GAMMA	200 ADVENTURE	90	GUERRERO	200 TUNDRA (VAR.)	83
GAMMA	250 EVER GREEN	109	GUERRERO	200 TUNDRA GXR (VAR. BAL. CORTO)	42
GILERA	100 AX	91	GUERRERO	250 GMX (CUSTOM)	110
GILERA	100 QM -9	52	GUERRERO	250 GRF (M.2012)	50
GILERA	110 C DLX (Ø54 - CAD.75 MM - P.A.RED.)	38	GUERRERO	70 FUTURE A/ELECT.	45
GILERA	110 ESTILO (Ø54 - CAD.75 MM - P.A.RED.)	38	GUERRERO	70 G A/ELECT.	45
GILERA	110 FUTURA (Ø54 - CAD.75 MM - P.A.RED.)	38	HONDA	100 C BIZ	51
GILERA	110 GLA (Ø54 - CAD.75 MM - P.A.RED.)	38	HONDA	100 HERO CD	52
GILERA	110 SMAH (Ø54 - CAD. 83 MM - P.A.OVAL.)	46	HONDA	100 WAVE NF	51
GILERA	110 SMASH (Ø54 - CAD.75 MM - P.A.RED.)	38	HONDA	105 BIZ (Ø54 - CAD.75 MM - P.A.RED.)	38
GILERA	110 SMASH (Ø54 - CAD.83 MM - P.A.RED.)	39	HONDA	110 WAVE	53
GILERA	125 FX (Ø54 - CAD. 83 MM - P.A.OVAL.)	46	HONDA	125 BIZ KS/ES M.2005	55
GILERA	125 GA	58	HONDA	125 BROSS	57
GILERA	125 REVOLUTION (P.A.RED.)	40	HONDA	125 CB1	54
GILERA	125 SPEEDY (SCOOTER)	28	HONDA	125 FAN	57
GILERA	125 SUPER	28	HONDA	125 STORM	56
GILERA	125 VC F/D	79	HONDA	125 TITAN M.2000	57
GILERA	150 GA	80	HONDA	125 TODAY	58
GILERA	150 VC STRADA (VAR.)	107	HONDA	125 XLR	58
GILERA	150 YL (CUSTOM BAL.)	41	HONDA	125 XR L M.2013	59
GILERA	200 SAHEL (VAR. BAL. CORTO)	42	HONDA	125 XR M.2012	56
GILERA	200 SAHEL (VAR. BAL. LARGO)	49	HONDA	125 XR R M.2013	59
GILERA	200 SMX (VAR. BAL. CORTO)	42	HONDA	150 AERO CBX	61
GILERA	200 SMX (VAR. BAL. LARGO)	49	HONDA	150 CG TITAN	60
GILERA	200 VARILLERA	83	HONDA	150 INVICTA CB	60
GILERA	200 VC (VAR. BAL. CORTO)	42	HONDA	150 NX	61
GILERA	200 VCR (CAD. BAL.)	43	HONDA	150 XR	60
GILERA	200 VCR (VAR. BAL.)	85	HONDA	190 CB	62
GILERA	200 YL (CHOPERA)	83	HONDA	200 CG (VAR.)	83
GILERA	250 CUSTOM	110	HONDA	200 NX (BRASIL)	64
GILERA	250 RR-15	72	HONDA	200 NX (JAPON)	63
GILERA	250 VCR	110	HONDA	200 STRADA CBX (BRASIL)	64
GILERA	275 YL	110	HONDA	200 STRADA CBX (JAPON)	63
GILERA	300 G1 RR	72	HONDA	200 XR (BRASIL)	64
GILERA	400 SMX	44	HONDA	200 XR (JAPON)	63
GUERRERO	100 G	52	HONDA	250 CBX TWISTER	65
GUERRERO	100 GD	51	HONDA	250 TORNADO	65
GUERRERO	100 MB	91	HONDA	400 NX FALCON M. '99	66
GUERRERO	100 WG BIKE	52	HONDA	400 XR	67
GUERRERO	110 BIKE (Ø54 - CAD.75 MM - P.A.RED.)	38	HONDA	400 NX FALCON	66
GUERRERO	110 DAY	103	IMSA	110 TRACK EVO (Ø54 - CAD.75 - P.A.RED.)	38
GUERRERO	110 FLASH (Ø54 - CAD. 83 MM - P.A.OVAL.)	46	IMSA	150 ROAD	80
GUERRERO	110 FLASH (Ø54 - CAD.75 MM - P.A.RED.)	38	JAWA	250 RVM TEKKEK	68
GUERRERO	110 FLASH (Ø54 - CAD.83 MM - P.A.RED.)	39	JAWA	300 6 (SIN BAL.)	69
GUERRERO	110 FUTURE (Ø54 - CAD.75 MM - P.A.RED.)	38	JAWA	300 9 (SIN BAL.)	69
GUERRERO	110 G DL (Ø54 - CAD.75 MM - P.A.RED.)	38	JAWA	300 E (SIN BAL.)	69

INDICE - Motos y Cuatriciclos



Marca	Modelo	Pág.	Marca	Modelo	Pág.
JAWA	350 9 (CON BAL.)	71	MONDIAL	150 RD (VAR.)	80
JAWA	350 9 (SIN BAL.)	70	MONDIAL	150 TD	80
JAWA	350 BOBBER (CON BAL.)	71	MONDIAL	200 RD (VAR.)	83
JAWA	350 BOBBER (SIN BAL.)	70	MONDIAL	200 TD (BAL.)	49
JAWA	350 DAYTONA (CON BAL.)	71	MONDIAL	200 TD (VAR.)	83
JAWA	350 DAYTONA (SIN BAL.)	70	MONDIAL	250 HD CUSTOM	110
JAWA	350 RUTA 40 (CON BAL.)	71	MONDIAL	254 HD	110
JAWA	350 RUTA 40 (SIN BAL.)	70	MOTOMEL	100 AX	91
JAWA	350 SPYDER (CON BAL.)	71	MOTOMEL	110 BIT (Ø54 - CAD.75 MM - P.A.RED.)	38
JAWA	350 SPYDER (SIN BAL.)	70	MOTOMEL	110 C DLX (Ø54 - CAD.75 MM - P.A.RED.)	38
JANSHE	125 F (CUB)	96	MOTOMEL	110 CLIPPER (Ø54 - CAD.75 MM - P.A.RED.)	38
JANSHE	125 JS 6B STREET M.2011/13	97	MOTOMEL	110 FD (Ø54 - CAD.75 MM - P.A.RED.)	38
JANSHE	125 M.N.	97	MOTOMEL	110 MAX	103
KAYAC	150	47	MOTOMEL	125 BLITZ	40
KAYAC	250	50	MOTOMEL	125 CG	79
KEEWAY	150 RKS	93	MOTOMEL	125 SKORPION	40
KELLER	110 BIG (Ø54 - CAD.75 MM - P.A.RED.)	38	MOTOMEL	125 SL	81
KELLER	110 CRONO CLASSIC (Ø54 - CAD.75 - P.A.RED.)	38	MOTOMEL	125 TOP (CUBS)	40
KELLER	110 TITAN (Ø54 - CAD.75 MM - P.A.RED.)	38	MOTOMEL	125 TOP (VAR.)	79
KELLER	125 CRONO TRIAL	40	MOTOMEL	125 X3M	79
KELLER	150 CONQUISTAR	81	MOTOMEL	150 CUSTOM (CAD.)	47
KELLER	150 E-XTREME	81	MOTOMEL	150 HD (VAR.)	80
KELLER	150 KN STRATUS	107	MOTOMEL	150 SKUA (VAR.)	80
KELLER	200 MIRACLE	83	MOTOMEL	150 TCP (VAR.)	107
KELLER	250 EXCELENCE	110	MOTOMEL	150 VX	81
KELLER	250 QUAD RACER	87	MOTOMEL	200 CUSTOM (VAR.)	83
KELLER	260 MX	72	MOTOMEL	200 DAKAR (BAL.)	49
KELLER	260 QUASAR	73	MOTOMEL	200 DAKAR (CAD.)	82
KELLER	260 R (HASTA M. 2013)	73	MOTOMEL	200 DAKAR (VAR.)	83
KELLER	260 RACING K2/NAKED (BAL.)	74	MOTOMEL	200 KS PISTERA (VAR. BAL.)	85
KELLER	260 STRATUS	73	MOTOMEL	200 SIRIUS	84
KONISA	110 MAGNIFIKA (Ø54-CAD.75 MM-P.A.RED.)	38	MOTOMEL	200 SKUA (CAD. BAL.)	43
KONISA	110 TUCUBIZ (Ø54 - CAD.75 MM - P.A.RED.)	38	MOTOMEL	200 SKUA MOTARD (VAR. BAL. CORTO)	42
KONISA	125 CITIZEN	40	MOTOMEL	200 SKUA MOTARD (VAR. BAL. GRANDE)	85
KONISA	125 KONISTAR	40	MOTOMEL	200 SKUA MOTARD M.2010 (VAR. BAL.)	85
KONISA	125 KONITOP	40	MOTOMEL	200 SR (CAD. BAL.)	82
KONISA	125 LF	77	MOTOMEL	200 SR (CAD.)	43
KTM	200 DUKE	75	MOTOMEL	200 SR (VAR.)	83
KTM	390 DUKE	76	MOTOMEL	200 TCP (CAD. BAL.)	43
KYMCO	110 ACTIV (Ø54 - CAD.75 MM - P.A.RED.)	38	MOTOMEL	250 HAWKER	110
KYMCO	125 SECTOR	58	MOTOMEL	250 MEGELLI (CAD.)	50
MAVERICK	110 H (Ø54 - CAD.75 MM - P.A.RED.)	38	MOTOMEL	250 QUEST (PARRILERO)	109
MAVERICK	125 CITY (VAR.)	79	MOTOMEL	250 RIDER	110
MAVERICK	125 SUPRA	40	MOTOMEL	250 SKUA (VAR. BAL.)	85
MAVERICK	150 STREET	107	MOTOMEL	250 TRACKER	110
MAVERICK	200 DUAL MOTARD (BAL.)	49	MOTOMEL	250 VOLKANO	87
MAVERICK	250 PANTHER	87	MOTOMEL	250 XMM (CAD. BAL.)	86
MONDIAL	256	87	MOTOMEL	250 XMM (VAR. BAL.)	85
MONDIAL	100 2T.	91	MOTOMEL	250 XPLORA	87
MONDIAL	110 LD (Ø54 - CAD.75 MM - P.A.RED.)	38	MOTOMEL	250 XPLORA (VAR. BAL.)	85
MONDIAL	110 LD 3 VALVULAS	104	MOTOMEL	70 ECO A/ELECT.	45
MONDIAL	115 AX	91	NANFANG	100 JIMNA FN	52
MONDIAL	125 LD	40	OKINOI	125	40
MONDIAL	125 MD/HD	77	OKINOI	150 NAKED	107
MONDIAL	125 RD (VAR.)	77	OKINOI	150 R	107
MONDIAL	150 EX K	78	OKINOI	150 ST STREET	107
MONDIAL	150 HD	80	OKINOI	250 MOTARD	87
MONDIAL	150 HD (SCOOTER)	81	PANTHER	250	89



INDICE - Motos y Cuatriciclos

Marca	Modelo	Pág.
PANTHER	200 M.N.	88
PITBULL	200	90
Q. AX	100 CHINA	91
Q. JIAM	100	91
SCOUT	250 C MAX	87
SUMO	125 CG (VAR.)	79
SUMO	150 RAPID	107
SUMO	200 SL	83
SUMO	250 RINO	87
SUZUKI	100 AX	91
SUZUKI	115 AX	91
SUZUKI	125 AN	92
SUZUKI	125 EN	93
SUZUKI	160 GIXXER	94
VESPA	150 PHANTOM (SCOOTER)	81
YAMAHA	100 CRYPTON	95
YAMAHA	105 CRYPTON	95
YAMAHA	110 NEW CRYPTON	96
YAMAHA	125 XTZ	97
YAMAHA	125 YBR	97
YAMAHA	150 R15	98
YAMAHA	160 FZ 16	99
YAMAHA	250 XTZ	100
YAMAHA	250 YBR	100
YAMAHA	250 YS	100
YAMAHA	350 RAPTOR	101
YAMAHA	350 WARRIOR	101
YAMAHA	400 WR	102
YAMAHA	400 YZF	102
YAMAHA	426 YZF	102
ZANELLA	110 BUSUNESS	103
ZANELLA	110 DUE (Ø54 - CAD.75 MM - P.A.RED.)	38
ZANELLA	110 SEXY (Ø54 - CAD.75 MM - P.A.RED.)	38

Marca	Modelo	Pág.
ZANELLA	110 SWING (Ø54 - CAD.75 MM - P.A.RED.)	38
ZANELLA	110 VENTO 2V. (Ø54 - CAD.75-P.A.RED.)	38
ZANELLA	110 VENTO 3 VALVULAS	104
ZANELLA	110 ZB 2V. (Ø54 - CAD.75 MM - P.A.RED.)	38
ZANELLA	110 ZB 3 VALVULAS	104
ZANELLA	125 DUE	40
ZANELLA	125 HJ	57
ZANELLA	125 RACER	105
ZANELLA	125 RX M.NVO.	79
ZANELLA	125 SAPUCAI 4T.	79
ZANELLA	125 SEXY	40
ZANELLA	125 ZB	105
ZANELLA	125 ZSC	81
ZANELLA	150 CECATTO	106
ZANELLA	150 HJ	80
ZANELLA	150 RX (CAD.)	61
ZANELLA	150 RX (VAR. BAL.)	41
ZANELLA	150 RX (VAR.)	107
ZANELLA	200 RX (VAR.)	83
ZANELLA	200 RX NAKED (BAL.)	49
ZANELLA	200 Z MAX TRUCK	108
ZANELLA	200 ZTT (VAR.)	83
ZANELLA	250 FX SCORPION	87
ZANELLA	250 G FORCE (M.N.)	109
ZANELLA	250 PATAGONIA EAGLE (CUSTOM)	110
ZANELLA	250 STYLER	111
ZANELLA	300 FX MAD MAX	72
ZANELLA	350 CHOPPER	71
ZANELLA	350 RX NAKED	71
ZANELLA	350 RZ 35R	71
ZANELLA	400 FX	101
ZANELLA	70 TRICARGO	45

EXHIBIDORES

JUNTAS TAPA DE VÁLVULAS

9808

Incluye!!

10 c/u

- Yamaha FZ 16
- Honda CG 150
- Appia Brezza 150

Incluye!!

5 c/u

- Honda Tornado 250
- Honda Wave 110



JUNTAS TAPA DE VÁLVULAS

9810

Incluye!!

10 c/u

- Honda Today 125
- Honda CB1 125

Incluye!!

5 c/u

- Honda CB 250
- Bajaj Rouser 135
- Bajaj NS 200



9800

66 medidas diferentes
Color NEGRO

Serie Standard

1,78 mm
2,62 mm
3,53 mm



En Cilindro Honda Biz y otras

12-7485 - Canal Aceite Tapa Cil. (18,5 x 14,5 mm)
12-7486 - Canal Aceite Base Cil.
12-7487 - Canal Aceite Tapa Cil. (12 x 9 mm)

Cubas de Carburador

12-7547 - Ciclomotor Etc...
12-7544 - Honda Wave 100 Etc.
12-7593 - Honda Econo/Biz - Smash Etc.
12-7633 - Honda Today/Titan 125 Etc.

9804

- Honda Elite LX 50
- Honda Elite CH 150
- Honda Kinetic 100
- Honda NS 50
- Honda CB 650
- Honda MTX 125 / 200
- Bajaj Rouser NS 200
- Zanella JR 200
- Daelim 50 Liberty
- Mondial M1 50
- Suzuki AE 50
- Bajaj Rouser 150 a 200
- Za. Due/V3 50 (1,5 mm)
- Za. Due/V3 50 (3 mm)
- Mo. Pumita 50 (1,5 mm)
- Mo. Pumita 50 (3 mm)
- Ga. Noi/Team 50 (1,5 mm)
- Ga. Noi/Team 50 (3 mm)
- Za. Sol 50 (1,5 mm)
- Za. Sol 50 (3 mm)
- Za. Sol Plus 70 (1,5 mm)
- Za. Sol Plus 70 (3 mm)

Incluye!!
10 c/u

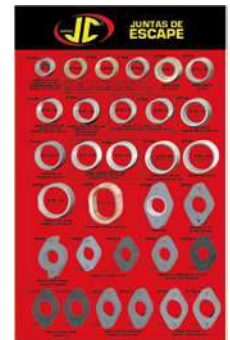

Incluye!!
30 c/u

- Gilera Smash 110 y otras..

Incluye!!
20 c/u

- Honda CG/Today 125 y otras...

- Honda Tornado/Twister 250 y otras...

Incluye!!
5 c/u

- Kawasaki KLR 600/650

9802

Incluye!!
10 c/u



- Honda Dax 70
- Honda Econo C 90
- Honda Biz C 100
- Gilera Smash 110
- Appia Vectra 110
- Guerrero Flash 110
- Yamaha Crypton 100/105
- Honda Biz 125 KS/KE M.2005
- Gilera Revolution 125 P.A.Red.
- Gilera Revolution 125 P.A.Oval.

9806

Incluye!!
10 c/u



- Honda CG/Today 125
- Honda Titan/Storm/Fan/Bross 125
- Honda CB1 125
- Honda Wave 110
- Honda Titan 150
- Gilera Smash Revolution 125
- Potenciada de 110 c.c. a 125 c.c.
- Motomel Dakar 200 (Var.)
- Motomel Dakar 200 (Cad.)
- Motomel Dakar 200 (Bal.)/Tundra 200 (Bal.)



TACOS GOMA MAZA

12-7301

CAUCHO NATURAL



Honda
ECONO C90
Gilera
Smash 100/110
y otras...

12-7302

CAUCHO NATURAL



Honda
BIZ C 100/C 105
WAVE 100
y otras...

12-7303

CAUCHO NATURAL



Honda
STORM 125
Yamaha
V 80 / YBR 125
ZANELLA
RX 150 y otras...

12-7304

CAUCHO NATURAL



Appia
VECTRA 110
Suzuki
AX 100/115
y otras...

12-7305

CAUCHO NATURAL



Yamaha
CRYPTON
100/105
y otras...

12-7306

CAUCHO NATURAL



Bajaj
ROUSER 135
180/200/220
y otras...

12-7307

CAUCHO NATURAL



Honda
CG 150 TITAN
y otras...

12-7308

CAUCHO NATURAL



Honda
TWISTER 250

12-7309

CAUCHO NATURAL



Honda
- **BIZ 125 KS/ES**
M.2005
- **NEW WAVE 110**

SEGURO DE CORONA

**HONDA
ECONO C 90
BIZ 100/105
GILERA
SMASH 100/110
y otras...**

6500

Paquete
x10



SEGURO DE CORONA

**HONDA
STORM 125
YAMAHA
CRYPTON 100/105
y otras...**

6501

Paquete
x10



ESTIRA CADENA



- Ø 12
- Ø 14
- Ø 16
- Ø 18

11-0112

11-0114

11-0116

11-0118

11-0412

Cuatriciclo



- Ø 12

Paquete
x10

ARANDELA TAPON DE ACEITE

**HONDA
ECONO C90/WAVE
GILERA
SMASH
y otras...**

ALUMINIO
ESP. 1,5 mm

11-0212

11-0214

Paquete
x10

12x20



14x20

ARANDELA GUIA O RING

**HONDA
ECONO C90/WAVE
GILERA
SMASH
y otras...**

11-0303

METAL
ESP. 1,5 mm



Paquete
x10

GOMA MANUBRIO

**GILERA
SMASH
GUERRERO
TRIP
y otras...**

GOMA Y TELA
ESP. 2,5 mm

11-0301

14 x 30 mm



Paquete
x10

JUNTA UNION ESCAPE

- HONDA
- SUZUKI
- KAWASAKI
- YAMAHA
- Y OTRAS...

Resiste
1000 °C

11-0002

5 cm de ancho
Esp. 1,5 mm



TAPON TENSOR DIST. (FLAUTIN)

**HONDA
ECONO C90/BIZ/WAVE
GILERA
SMASH 100/110
y otras...**

11-0302

Paquete
x10



SELLA JUNTAS

CARACTERÍSTICAS GENERALES

Es un adhesivo sintético, de secado por evaporación y temperatura especial para juntas.
Actúa como sellador en las bombas de Agua, Cajas de Velocidad, Carter, Tapas de Distribución, Tapas de Válvulas, etc..
No es un cemento de contacto.
No tiene tolueno.
No se solidifica produciendo rajaduras y posibles pérdidas.
Al ser utilizado en juntas en donde se desarrollan temperaturas elevadas pega automáticamente sin cristalizar.

7181

Paquete
x12



SEP. ANTIRUIDO EN ENCARENADOS

- 6 X 15 mm
- 8 x 16 mm
- 10 x 18 mm

11-0206

11-0208

11-0210

Paquete
x50

Precio x Unidad

GOMA
ESP. 2,5 mm



RETEN ENCENDIDO

12-7201

**HONDA
TODAY
TITAN 125
Y OTRAS**



22 x 35 x 7 mm
NITRILO
DUREZA: 70 Shore

RETEN ENC. CHICO

12-7202

**HONDA
BIZ C 100
GILERA
SMASH 110
Y OTRAS**



18,9 x 30 x 5 mm
NITRILO
DUREZA: 70 Shore

RETEN ENC. GRANDE

12-7203

**HONDA
BIZ C 100
GILERA
SMASH 110
Y OTRAS**



30 x 42 x 4,5 mm
NITRILO
DUREZA: 70 Shore

KIT ENCENDIDO

9-637

**HONDA
TODAY
TITAN 125
Y OTRAS**



KIT ENCENDIDO

9-630

**HONDA
BIZ C 100
GILERA
SMASH 110
Y OTRAS**



KIT O'RING TAPA DE CIL.

9-638

**HONDA
BIZ C 100
GILERA
SMASH 110
Y OTRAS**

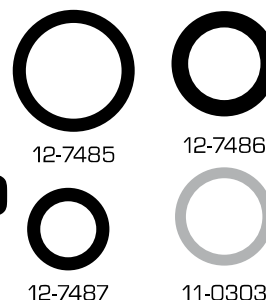

TAPAS y BASES en COBRE (COMPETICION)

Tapas y Bases de Cilindro en COBRE para

Motos tipo BIZ / SMASH / TITAN / RX 150 y otras...

Código - Material

(Código) **B - COBRE Esp. 0,1 mm**

(Código) **C - COBRE Esp. 0,2 mm**

(Código) **D - COBRE Esp. 0,3 mm**

(Código) **E - COBRE Esp. 0,4 mm**

(Código) **F - COBRE Esp. 0,5 mm**

Ej: Tapa cilindro Smash 110

07847 C - COBRE Esp. 0,2 mm

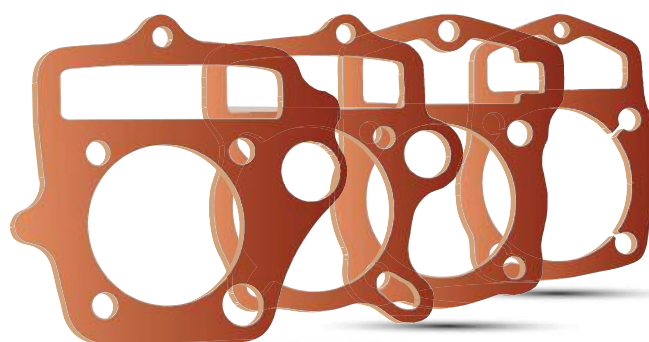

Bases de Cilindro - Material: Alma Metal

Sistema de sellado altamente efectivo consta de un soporte metálico revestido a ambos lados por material Premium.

Este metal ubicado en el alma de la junta ayuda a la tracción, compresión y recupero del material después del torque.

Metal



Material
Premium

Metal

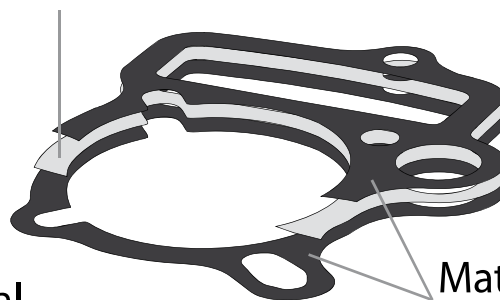

Material
Premium

Para pedir cualquier Base de Cilindro en este material solo debe agregar al número del código las letras "A/M"
Ej: **07846 A/M - BASE CIL. GILERA SMASH 110**



TEAR OFF'S

SCOTT (GRANDE)

149 mm

T07182

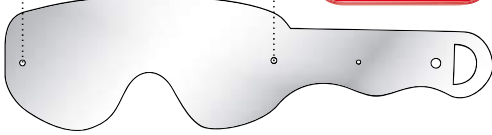

SCOTT (CHICO)

154 mm

T07183

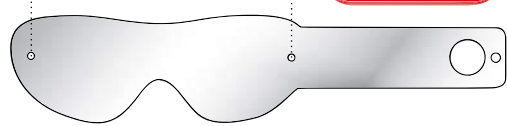

SCOTT QUICK LOAD

T07184

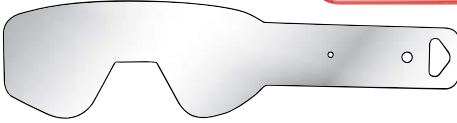

PROGRIP

148 mm

T07185

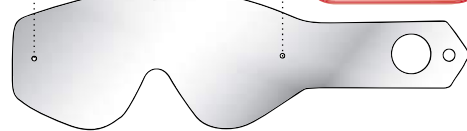

SMITH

154 mm

T07186

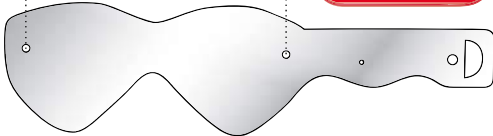

SPY

140 mm

T07187

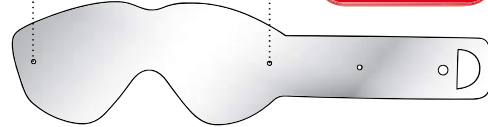

ARNETTE

157 mm

T07188

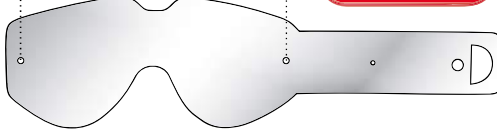

THOR

176 mm

T07189

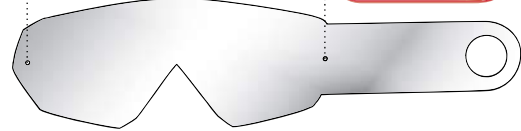

SCOTT 80 S

152 mm

T07190

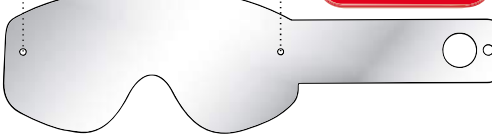

SCOTT VOLTAGE

152 mm

T07191

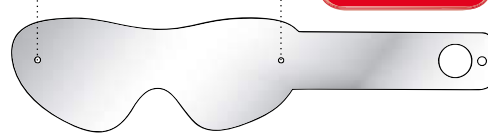

OAKLEY COWBAR

176 mm

T07192

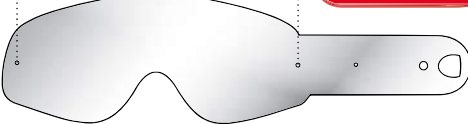

X - BRAND

170 mm

T07193

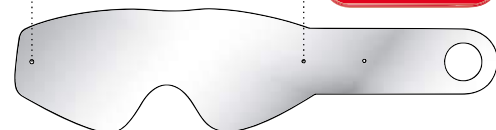

SCOTT SERIE 80 WORKS

155 mm

T07194

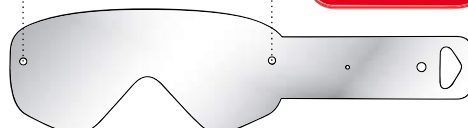

H VOLTAGE WORK

155 mm

T07195

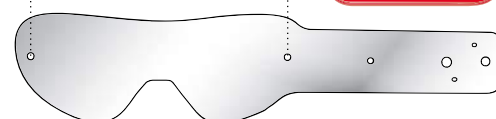

TEAR OFF'S



OAKLEY OFRAME

176 mm

T07196

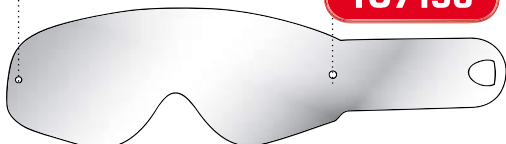

BRAND JUNIOR

150 mm

T07197

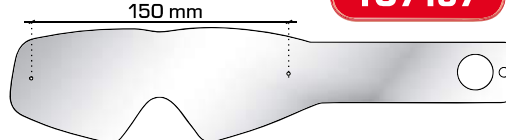

DRAGON MDX

176 mm

T07198

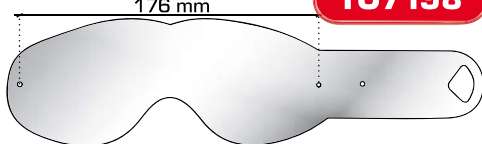

DRAGON VENDETTA

172 mm

T07199

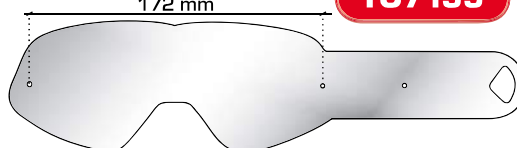

FOX X

169 mm

T07200

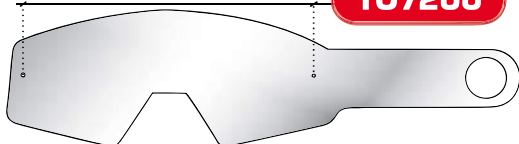

100 %

163 mm

T07201

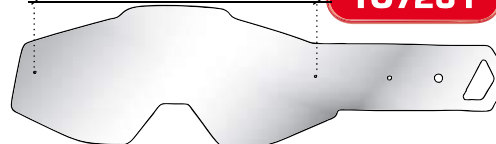

SLAYER PRO UTOPIA

165 mm

T07202

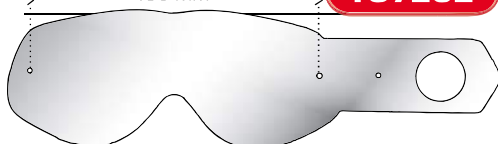

FOX M.N. AIR SPC

184 mm

T07203

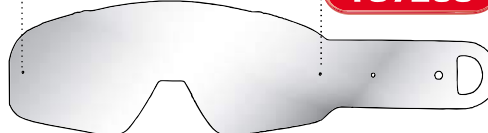

SPY

170 mm

T07204

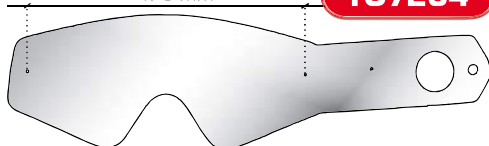

ARAI GP6

T07205

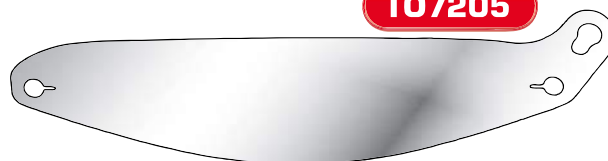

OAKLEY AIRBRAKE

160 mm

T07207

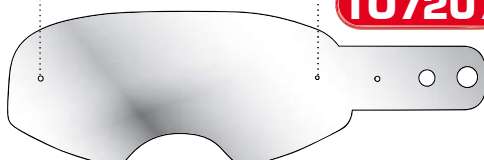

FLY

175 mm

T07208

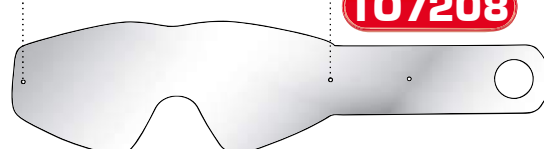

X BRAND 18 EKS-S

175 mm

T07209

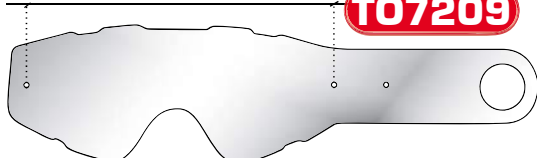



TAPAS DE VÁLVULAS

12-7545

HONDA
**CG/TODAY
TITAN 125**
Y OTRAS...

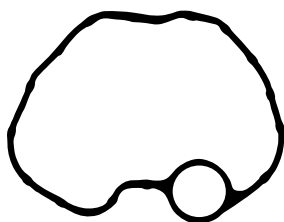

12-7750

APPIA
BREZZA 150
Y OTRAS...

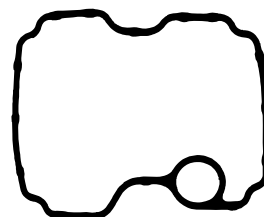

12-7650

HONDA
CG 150 TITAN
Y OTRAS...

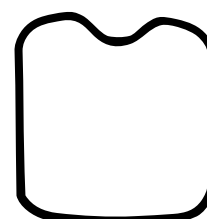

12-7751

HONDA
**CB 250
NIGHTWAWK**
Y OTRAS...

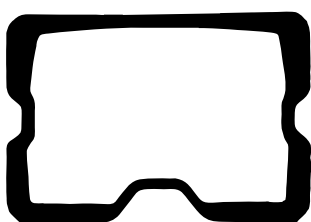

12-7752

YAMAHA
FZ 16
Y OTRAS...

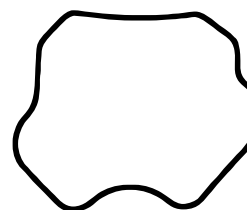

12-7753

HONDA
**TORNADO 250
TWISTER CBX 250**
Y OTRAS...

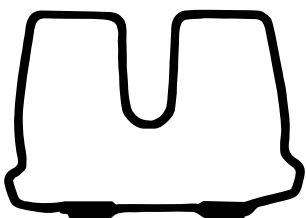

12-7754

HONDA
CB 1 125
Y OTRAS...

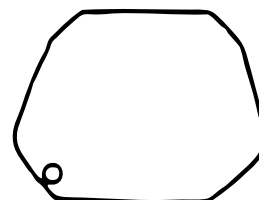

12-7755

HONDA
WAVE 110
Y OTRAS...

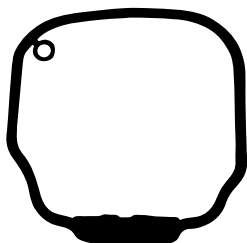

12-7756

BAJAJ
ROUSER 135

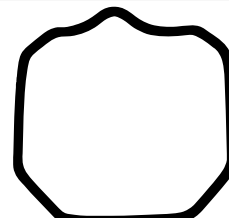

12-7757

BAJAJ
**ROUSER
200 NS**

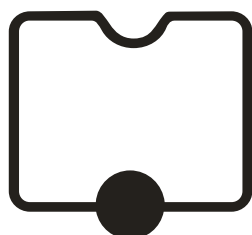

12-7758

HONDA
CB 190

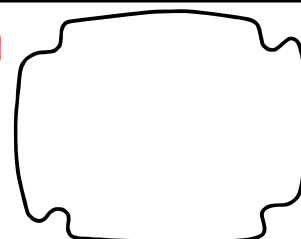

CUBAS DE CARBURADOR

CICLOMOTORES



12-7547

HONDA
ECONO/BIZ/HERO
Y OTRAS...

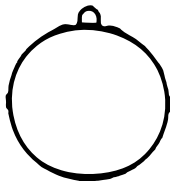

12-7593

HONDA
WAVE 100
Y OTRAS

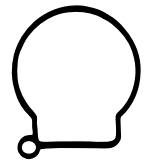

12-7544

HONDA
CG 125/TODAY
Y OTRAS...

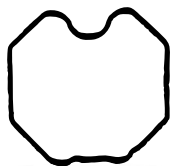

12-7633

BAJAJ
ROUSER 135
Y OTRAS

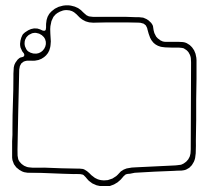

12-7635

TAPA DISTRIBUCION

BOMBA DE AGUA

HONDA
CB1 125

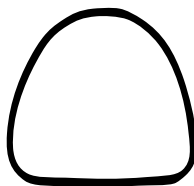

12-7594

BAJAJ
ROUSER 200 NS

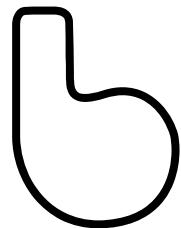

12-7595

TAPAS DE CILINDRO - CUATRICICLOS

Gamma 200 M.N / 250 M.N.

24400 A

MFT CON FONDO COBRE
ESP. 1,2 mm

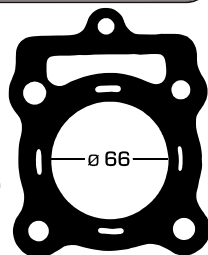

Gamma 200 / Motomel PITBULL 200

23548 M

METAL ESP. 0,22 mm

23548 A

MFT ESP. 1,2 mm

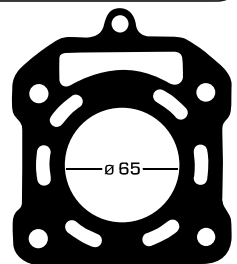

Guerrero 200 GSF-S MAPUCHE

23807 A

MFT CON FONDO COBRE
ESP 1,2 mm

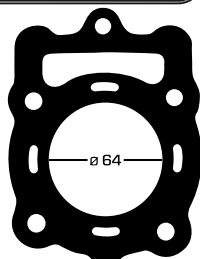

Motomel TRACKER 250

23892 A

MFT ESP. 1,20 mm

23892 M

METAL ESP. 0,22 mm

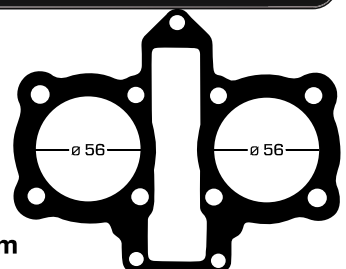



TAPAS DE CIL. - CUATRICICLOS

Panther 200

23797 M
METAL 3 LÁMINAS

23797 A
MFT ESP. 1,2 mm

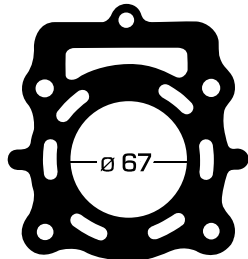

Panther 200 M.N.

23805 M
METAL ESP. 0,22 mm

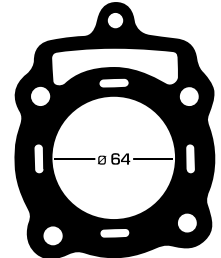

Panther 250

23782 M
METAL ESP. 0,22 mm

23782 A
MFT ESP. 1,2 mm

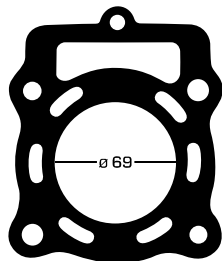

Rafter 200

23765 M
METAL 3 LÁMINAS

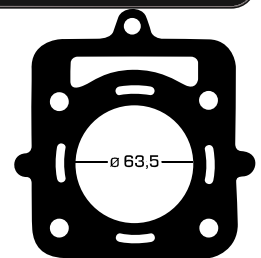

Yamaha YZF 450 R (Inyeccion) M.07/12

24484 M
Ø 96 - METAL 3 LÁMINAS

24485 M
Ø 99 - METAL 3 LÁMINAS

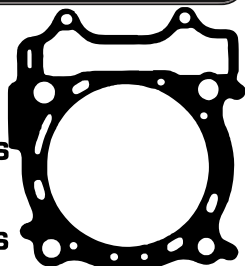

Zanella FX 200

23705 A
MFT C/FDO COBRE
ESP 1,2 mm

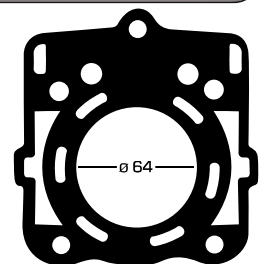

Zanella G-FORCE 250

23731 M
METAL 3 LÁMINAS

23731 A
MFT ESP. 1,2 mm

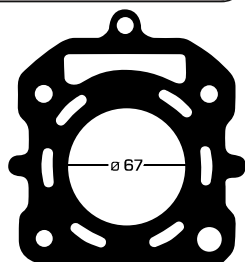

Zanella FX 250 SCORPION

23921 A
MFT ESP. 1,2 mm

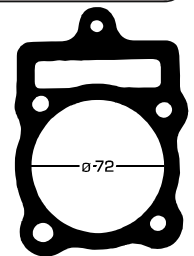

Zanella G-FORCE 250 M.N.

23958 M
METAL 3 LÁMINAS

23958 A
MFT ESP. 1,2 mm

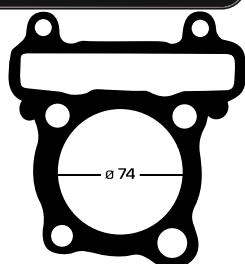

Za. FX 400/Ya. Raptor/Warrior 350

23957 M
METAL 3 LÁMINAS

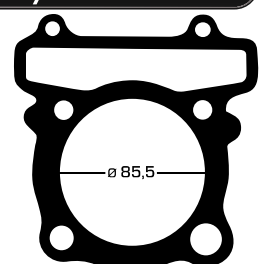

TAPAS CIL. MOTOS



Guerrero G 50 - Gilera C 50

02445 A

MFT ESP. 1,2 mm

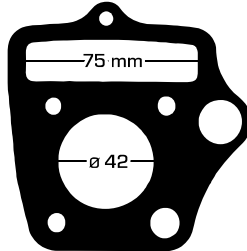

Honda Dax 70

01451 A

MFT ESP. 1,2 mm

01451 M

METAL 3 Láminas

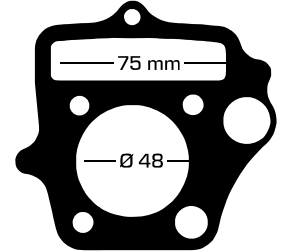

Honda ECONO C 90

01521 A

MFT ESP. 1,2 mm

01521 M

METAL 3 Láminas

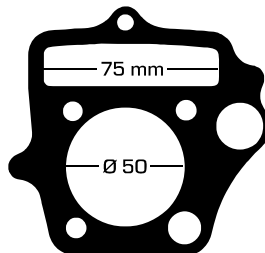

Honda BIZ C 100

01533 A

MFT ESP. 1,2 mm

01533 M

METAL 3 Láminas

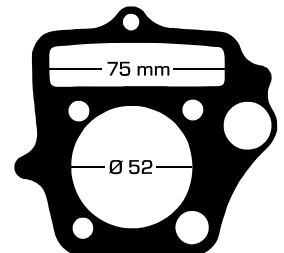

Gilera FUTURA 110 M.N.

08926 A

MFT ESP. 1,2 mm

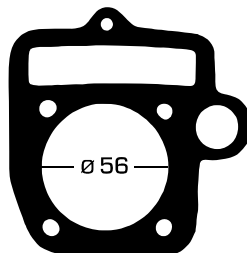

Gilera SMASH 110 Ø 54 CAD. 75 P.A.RED.

07847 A

MFT ESP. 1,2 mm

07847 M

METAL 3 Láminas

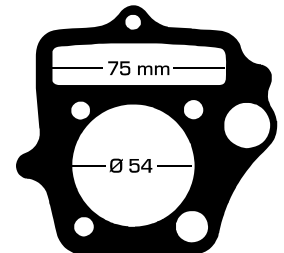

Gilera SMASH 110 Ø 50 CAD. 75 P.A.RED.

24482 A

MFT ESP. 1,2 mm

24482 M

METAL 3 Láminas

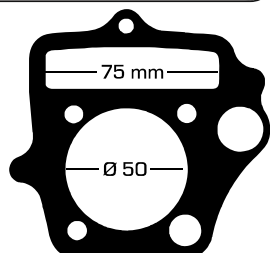

Gilera SMASH 110 Ø 52 CAD. 75 P.A.RED.

24483 A

MFT ESP. 1,2 mm

24483 M

METAL 3 Láminas

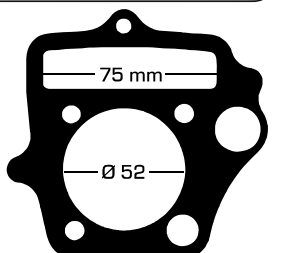

Gilera SMASH 110 Ø 50 CAD. 83 P.A.RED.

24478 A

MFT ESP. 1,2 mm

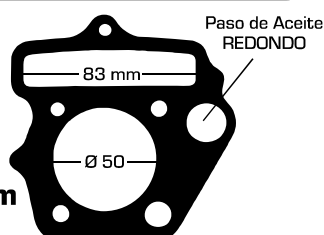

Gilera SMASH 110 Ø 50 CAD. 83 P.A.OVAL.

24479 A

MFT ESP. 1,2 mm

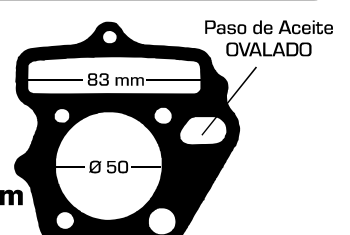



TAPAS CIL. MOTOS

Gilera SMASH 110 Ø 52 CAD. 83 P.A.RED.

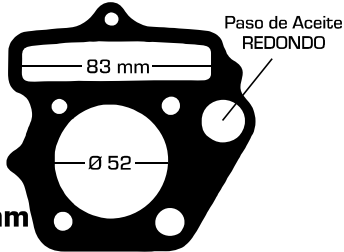

24480 A

MFT ESP. 1,2 mm

Gilera SMASH 110 Ø 52 CAD. 83 P.A.OVAL

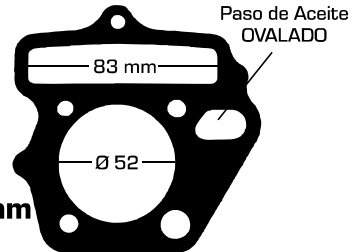

24481 A

MFT ESP. 1,2 mm

Guerrero TRIP 110 P.A.OVAL.

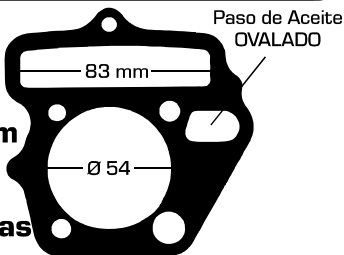

06650 A

MFT ESP. 1,2 mm

06650 M

METAL 3 Láminas

Guerrero TRIP 110 P.A.RED.

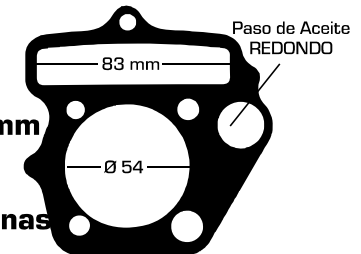

08865 A

MFT ESP. 1,2 mm

08865 M

METAL 3 Láminas

Potenciada de 110 a 125 c.c.

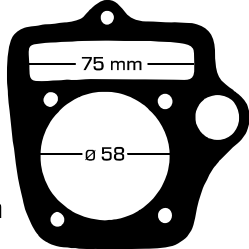

23750 A

MFT ESP. 1,2 mm

24518 M

METAL ESP. 0,22 mm

Gilera SMASH 110 Ø 56 Desp.

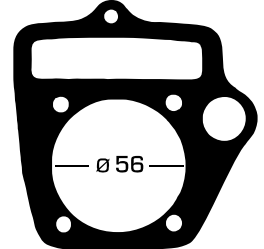

24518 A

MFT ESP. 1,2 mm

24518 M

METAL ESP. 0,22 mm

Bajaj XCD 125

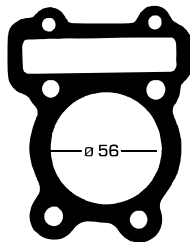

24002 M

METAL ESP. 0,22 mm

Bajaj ROUSER 135

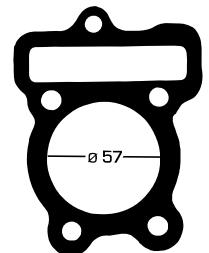

23994 M

METAL ESP. 0,22 mm

Bajaj ROUSER 150/180/200/220

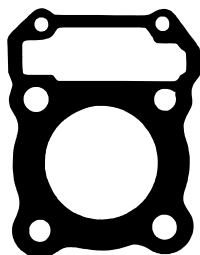

- 24010 M** ROUSER 150 - Ø60
- 24424 M** ROUSER 180 - Ø64
- 24017 M** ROUSER 200/220 - Ø68

Bajaj ROUSER 200 NS

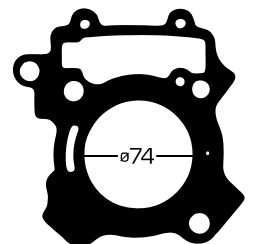

25193 M

METAL 3 Láminas

25193 A

MFT ESP. 1,2 MM

TAPAS CIL. MOTOS



Beta 200 MOTARD

24430 A

MFT ESP. 1,2 mm

24430 M

METAL 3 Láminas

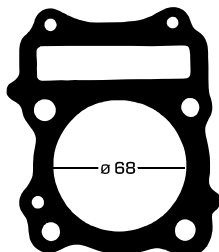

Corven EXPERT 80

25065 M

METAL ESP. 0,22 mm

25065 A

MFT ESP. 1,2 mm

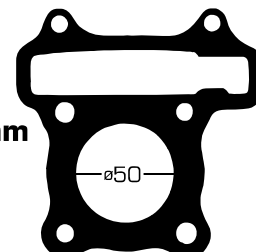

Gilera SUPER 125 M.N.

24038 M

METAL ESP. 0,22 mm

24038 A

MFT ESP. 1,2 mm

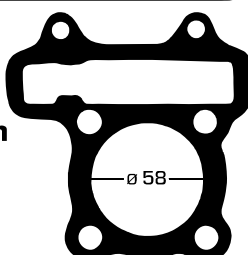

Gilera REVOLUTION P.A.OVAL.

23565 A

MFT ESP. 1,2 mm

23565 M

METAL 3 Láminas

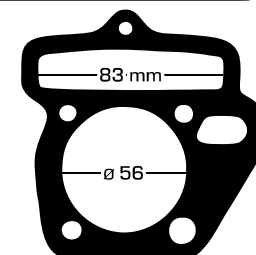

Gilera REVOLUTION P.A.RED.

24438 A

Ø 58 MFT ESP. 1,2 mm

24519 A

Ø 56 MFT ESP. 1,2 mm

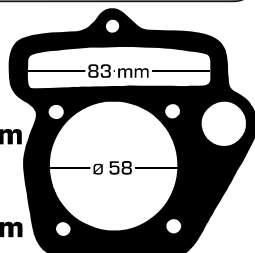

Gilera SMX 400

24487 A

METAL 3 LÁMINAS

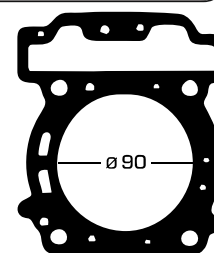

G.M. ANGEL 100.Ho. ELITE 125 M.2000

01355 M

METAL ESP. 0,22 mm

01355 A

MFT ESP. 1,2 mm

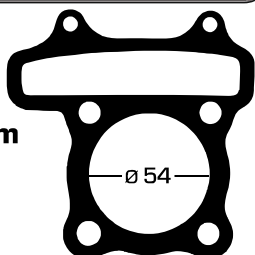

Guerrero TUNDRA 200 (Bal.)

23025 M

METAL ESP. 0,22 mm

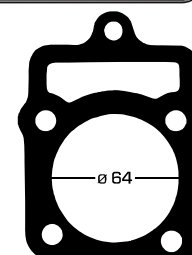

Honda BIZ 125

08927 A

MFT ESP. 1,2 mm

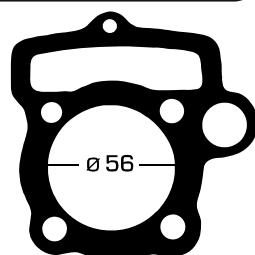

Honda BIZ 125 KS/ES M.2005

23947 A

MFT ESP. 1,2 mm

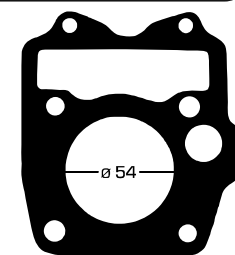



TAPAS CIL. MOTOS

Honda XL/CB 125

01625 A

MFT ESP. 1,2 mm

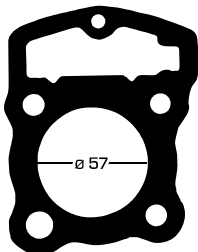

Honda TODAY 125

06691 A

MFT ESP. 1,2 mm

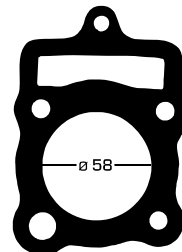

Honda TITAN 125 M.97/2001

06706 M

METAL ESP. 0,22 mm

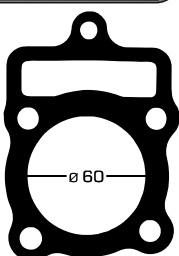

Honda NX 125

01643 A

MFT ESP. 1,2 mm

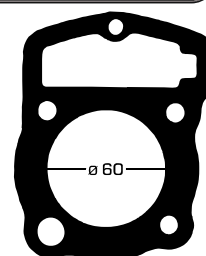

Honda CG 150 TITAN

08153 M

HONDA CG 150 Ø 60

25336 M

HONDA CG 190 Ø 66

25338 M

HONDA CG 220 Ø 71

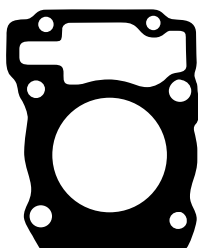

Honda NX 150

01707 A

MFT ESP. 1,2 mm

01707 M

METAL ESP. 0,22 mm

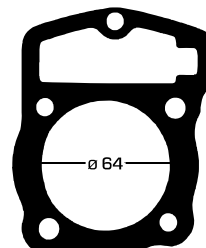

Honda CB 190

25341 M

HONDA CB 190

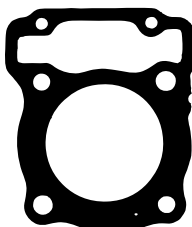

Honda XR 200 Japón

01782 A

MFT ESP. 1,2 mm

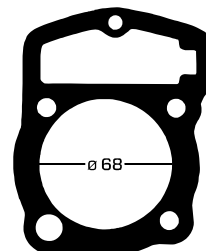

Honda XR 200 Brasil

23413 M

METAL ESP. 0,22 mm

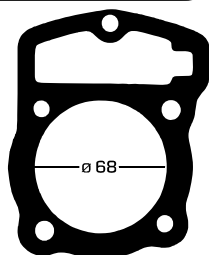

Honda CB 250 NIGHTHAWK

01896 A

MFT ESP. 1,2 mm

01896 M

METAL ESP. 0,22 mm

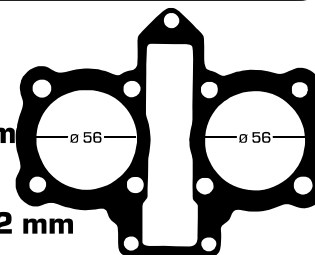

TAPAS CIL. MOTOS



Honda TORNADO/TWISTER 250 (Competición)

Código **Diámetro**

25220 - Ø 80
25366 - Ø 81
25367 - Ø 82
25221 - Ø 85
25222 - Ø 86
25223 - Ø 87
25224 - Ø 90
25225 - Ø 92
25226 - Ø 94
25227 - Ø 97

Tapa de Cilindro

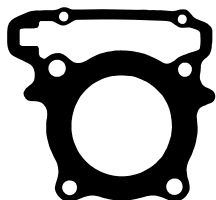

Material MFT

Código + A : Esp. 1,2
Código + B : Esp. 1,5
Código + C : Esp. 2,6

Ej: 25220 B
Tapa Cil. Tornado/Twister
Ø 80 MFT Esp. 1,5 mm
Ej: 25230 B
Base Cil. Tornado/Twister
Ø 88 MFT Esp. 1,5 mm

Base de Cilindro

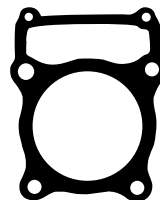

Código **Diámetro**

25465 - Ø 83
25230 - Ø 88
25231 - Ø 99

Honda XR 250 M. 87/99

01886 A

MFT ESP. 1,2 mm

01886 M

METAL 3 Láminas

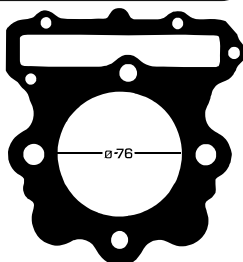

Honda TORNADO/TWISTER 250

23477 A

MFT ESP. 1,2 mm

23477 M

METAL 3 Láminas

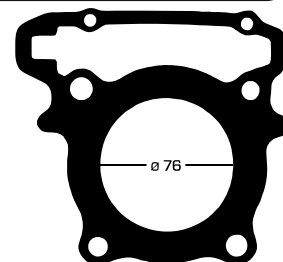

Honda NX 350 SAHARA

01943 M

METAL 3 Láminas

01943 A

MFT ESP. 1,2 mm

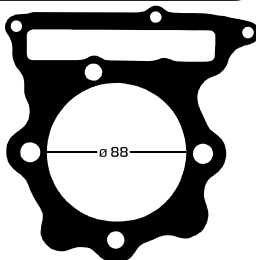

Honda XR 400

02023 A

MFT ESP. 1,2 mm

02023 M

METAL 3 Láminas

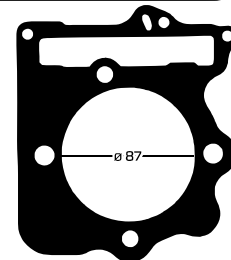

Honda NX 400 FALCON M.99

24476 A

MFT ESP. 1,2 mm

24476 M

METAL 3 Láminas

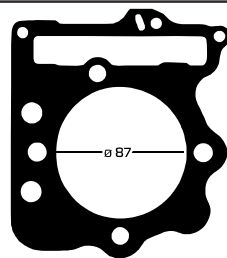

Honda XR 600

02079 A

MFT ESP. 1,2 mm

02079 M

METAL 3 Láminas

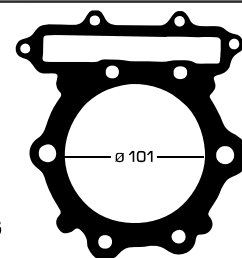

Honda XR/NX 650

02106 A

MFT ESP. 1,2 mm

02106 M

METAL 3 Láminas

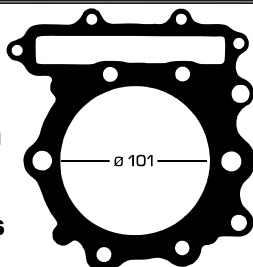

Jawa 300 E

25200 M

METAL ESP. 0,22 mm

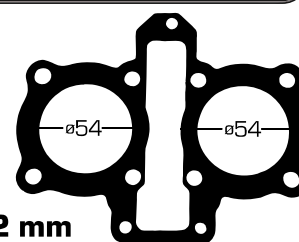



TAPAS CIL. MOTOS

Jawa 350 9

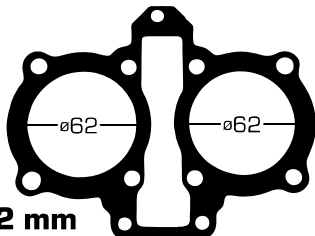

25201 M

METAL ESP. 0,22 mm

Kawasaki NEO MAX 100

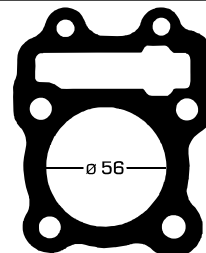

02414 A

MFT ESP. 1,2 mm

Kawasaki KAZER 100

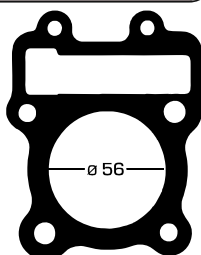

02447 M

METAL ESP. 0,30 mm

Kawasaki KDX 125

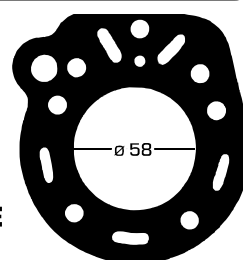

02529 A

MFT C/FONDO COBRE
ESP. 1,2 mm

Kawasaki KX 125 M. 94/96

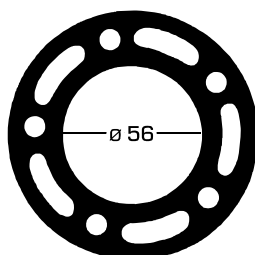

06822 A

MFT ESP. 1,2 mm

Kawasaki KX/KMX 125

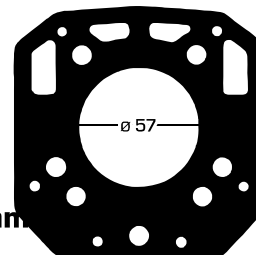

02468 A

MFT ESP. 1,2 mm

02468 M

METAL ESP. 0,22 mm

Kawasaki VICTOR 150

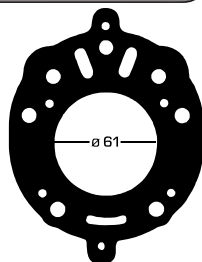

02489 A

MFT ESP. 1,2 mm

02489 M

METAL ESP. 0,30 mm

Kawasaki KDX/KX 250

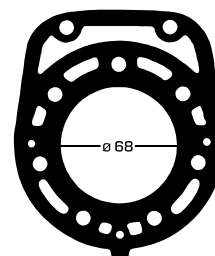

06830 A

MFT C/FONDO COBRE
ESP. 1,2 mm

Kawasaki KLR 600/650

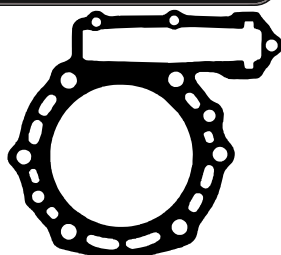

06839 A

KLR 600 - Ø 98
MFT ESP. 1,2 mm

02685 A

KLR 650 - Ø 102
MFT ESP. 1,2 mm

Keller MX 260

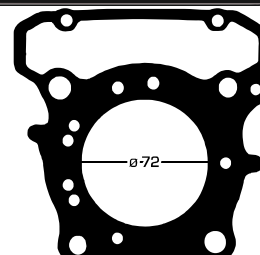

24096 M

METAL 3 Láminas

TAPAS CIL. MOTOS



Keller 260 RACING K2/NAKED (Bal.)

24103 A

MFT ESP. 1,2 mm

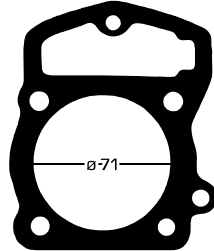

Keller STRATUS 260

24477 M

METAL 4 Láminas
Esp. 1,2 mm

24477 A

MFT Esp. 1,2 mm

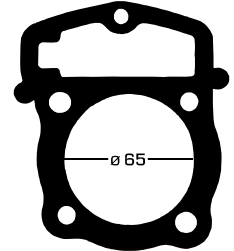

Kymco SPIKE 125

23656 A

MFT ESP. 1,2 mm

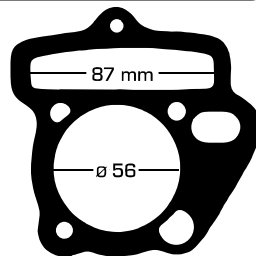

Kymco ACTIVE 125

22761 A

MFT ESP. 1,2 mm

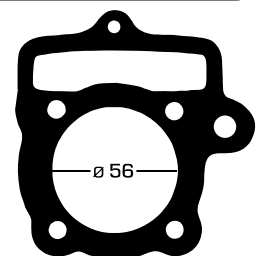

Kymco MXU 150 / Imsa ROAD 150

23956 A

MFT ESP. 1,2 mm

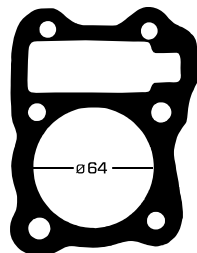

Motomel VX 150

08885 M

METAL ESP. 0,22 mm

08885 A

MFT ESP. 1,2 mm

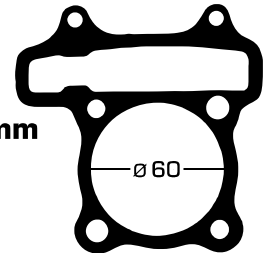

Motomel DAKAR 200 (Var.)

08883 A Ø 66 MFT ESP. 1,2 mm
08883 M Ø 66 METAL ESP. 0,22 mm
24520 A Ø 68 MFT ESP. 1,2 mm
24520 M Ø 68 METAL ESP. 0,22 mm
24467 A Ø 71 MFT ESP. 1,2 mm
24467 M Ø 71 METAL ESP. 0,22 mm

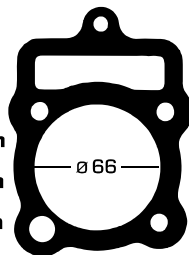

Motomel DAKAR 200 (Cad.)

08928 A Ø 71 MFT ESP. 1,2
08928 M Ø 71 METAL
24523 A Ø 66 MFT ESP. 1,2
24521 A Ø 68 MFT ESP. 1,2

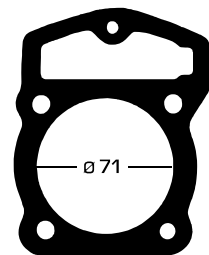

Motomel X3M 125

24236 A

MFT ESP. 1,2 mm

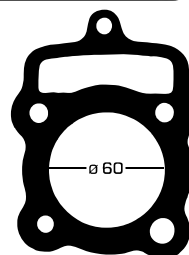

Motomel XPLORA 250

24265 A

Ø 71 MFT ESP. 1,2 mm

24522 A

Ø 68 MFT ESP. 1,2 mm

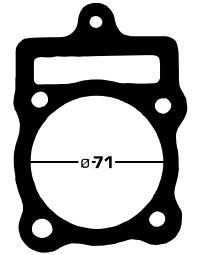



TAPAS CIL. MOTOS

Suzuki AX 100

03083 M

METAL ESP. 0,30 mm

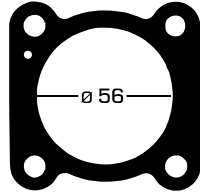

Suzuki 110 FX/FD LOVE

03120 A

MFT ESP. 1,20 mm

03120 M

METAL 3 LÁMINAS

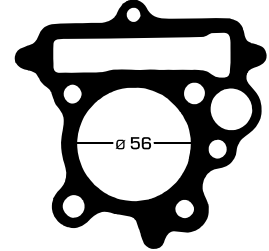

Suzuki DR 125

03134 A

MFT ESP. 1,2 mm

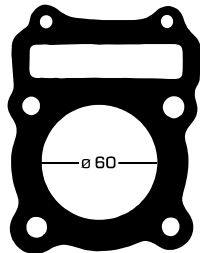

Suzuki EN 125

23771 M

METAL ESP. 0,22 mm

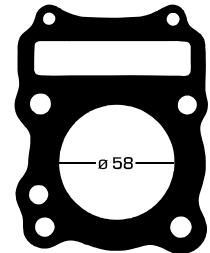

Suzuki DR 200

03264 A

MFT ESP. 1,2 mm

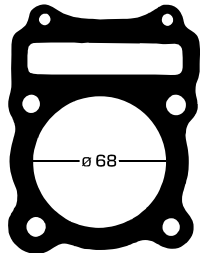

Suzuki DR 350 Hasta M.94

03431 A

MFT ESP. 1,2 mm

03431 M

METAL 3 Láminas

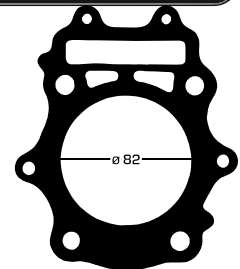

Yamaha CRYPTON 100/105

03851 M

METAL 1 LÁMINA

03851 A

MFT ESP. 1,2 mm

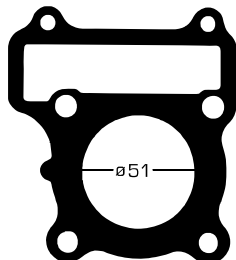

Yamaha NEW CRYPTON 110

24449 M

METAL 1 LÁMINA

24449 A

MFT ESP. 1,2 mm

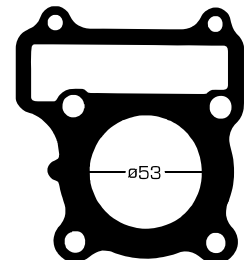

Yamaha YBR/XTZ 125

07118 M

METAL ESP. 0,22 mm

07118 A

MFT ESP. 1,2 mm

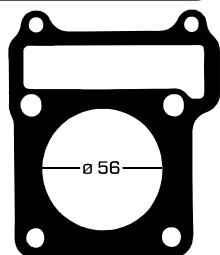

Yamaha FZ 16

23977 M

METAL ESP. 0,22 mm

23977 A

MFT ESP. 1,2 MM

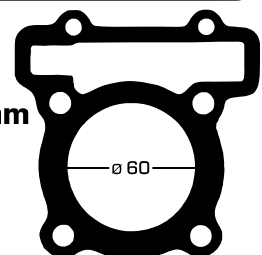

TAPAS CIL. MOTOS



Yamaha XT 225 SEROW

04016 A

MFT ESP. 1,2 mm

04016 M

METAL 3 Láminas

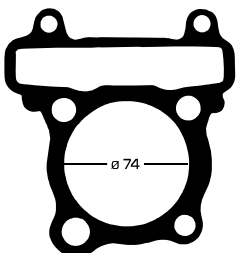

Yamaha YBR/XTZ 250

23790 M

METAL 3 LÁMINAS

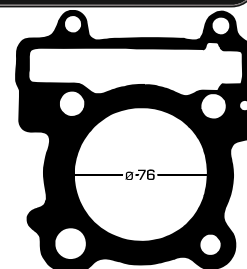

Yamaha XT 250 M.91

04086 A

MFT ESP. 1,2 mm

04086 M

METAL 3 Láminas

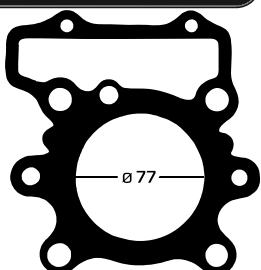

Yamaha XT 350 M.91

04135 A

MFT ESP. 1,2 mm

04135 M

METAL 3 Láminas

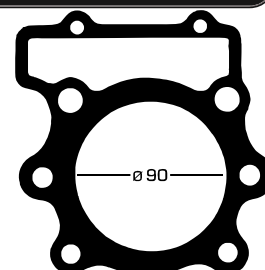

Yamaha XT 600 M.91/99

07163 M

METAL 3 Láminas

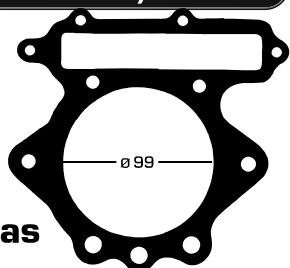

Yamaha TT 600

04188 M

METAL 3 Láminas

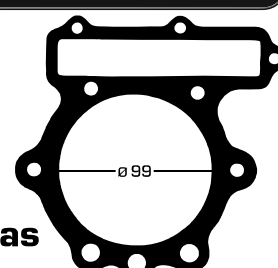

Zanella STYLER 50

24334 M

METAL ESP. 0,22 mm

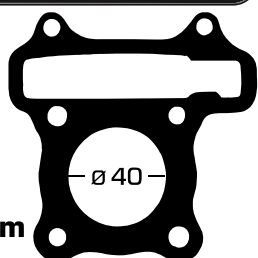

Zanella Vento/ZB 110 3 Valv.

08917 A

MFT ESP. 1,2 mm

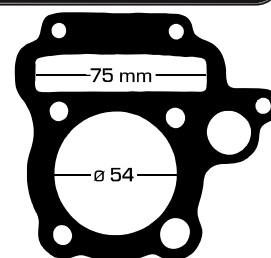

Zanella RX 150 (Var.)

23001 A

MFT ESP. 1,2 mm

23001 M

METAL ESP. 0,22 mm

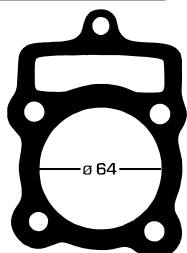

Zanella SCOOTER 150

24343 M

METAL ESP. 0,22 mm

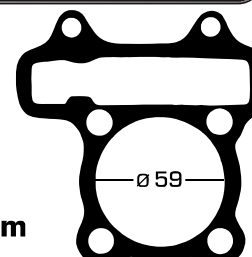



Motos y Cuatriciclos

20094 P - APPIA 150 BREZZA (BAL.)

Bases de Cil. ALMA METAL
incluidas en las líneas
PREMIUM y PREMIUM C/O RING



EQUIVALENTES	
APPIA: STRONGER 150 - MONTERO 150 M.N. (VAR. BAL.)	

CODIGO	UNIDAD	MATERIAL
20094 P	JUEGO COMPLETO	PREMIUM C/T. VALV.
20094 P/O	JUEGO COMPLETO	PREM. C/O'RING Y T/V
21095 P	CABEZA DE CILINDRO	PREMIUM
21095 P/O	CABEZA DE CILINDRO	PREM. C/O'RING Y T/V
23738 A/M	BASE DE CILINDRO	ALMA METAL
23739 A	TAPA DE CILINDRO	MFT
23739 M	TAPA DE CILINDRO	METAL
23740	ESCAPE	CHAPA
23741 P	ADMISION (2 X JGO)	PREMIUM
23742 P	EMBRAGUE	PREMIUM
23743 P	CARTER	PREMIUM
23744	BOMBA ACEITE	ADAMITE
23746 P	ENCENDIDO IZQ.	PREMIUM
23748 P	T/CENT. ACEITE	PREMIUM
12-7750	TAPA VALVULAS	NITRILO
9-609	KIT O'RING COMPLETO	NITRILO
8-609	KIT O'RING CABEZA CIL.	NITRILO

20094 P - Juego completo

21095 P - Cabeza de Cilindro

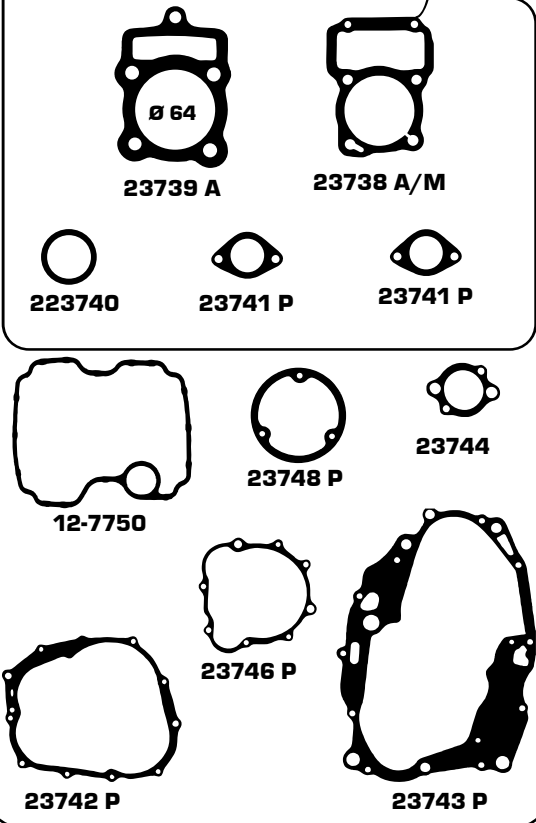

9-609 - Kit O'ring Completo

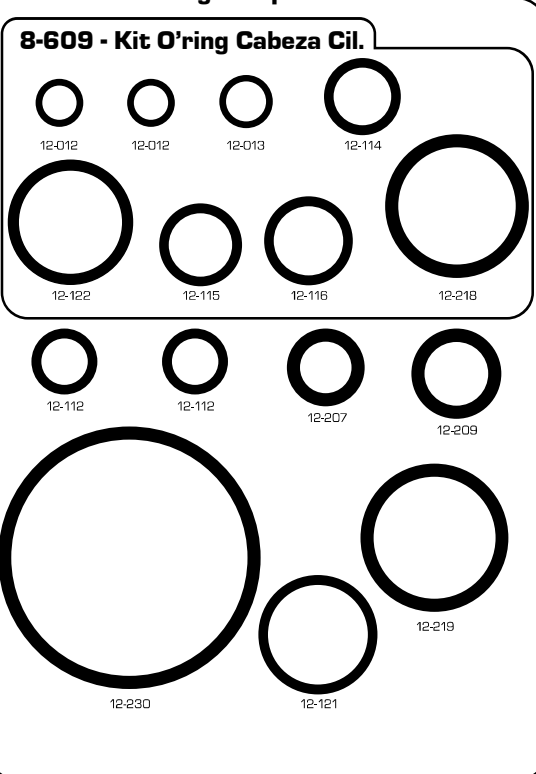

20003 P - APPIA 150 MONTERO (M. VJO.)

Bases de Cil. ALMA METAL
incluidas en las líneas
PREMIUM y PREMIUM C/O RING



EQUIVALENTES	
APPIA: MONTERO 150 M.08/09 - BLESS 150	

CODIGO	UNIDAD	MATERIAL
20003 P	JUEGO COMPLETO	PREMIUM C/T. VALV.
20003 P/O	JUEGO COMPLETO	PREM. C/O RING Y T/V
21041 P	CABEZA DE CILINDRO	PREMIUM
21041 P/O	CABEZA DE CILINDRO	PREM. C/O RING Y T/V
22964 A/M	BASE DE CILINDRO	ALMA METAL
22965 A	TAPA DE CILINDRO	MFT
22965 M	TAPA DE CILINDRO	METAL
22966	ESCAPE	CHAPA
22967 P	ADMISION	PREMIUM
22968 P	EMBRAGUE	PREMIUM
22969 P	CARTER	PREMIUM
22970	BOMBA ACEITE	ADAMITE
22972 P	ENCENDIDO IZQ.	PREMIUM
22974 P	T/CENT. ACEITE	PREMIUM
12-7545	TAPA VALVULAS	NITRILO
9-609	KIT O RING COMPLETO	NITRILO
8-609	KIT O RING CABEZA CIL.	NITRILO

20003 P - Juego completo

21041 P - Cabeza de Cilindro



22965 A



22964 A/M



22966



22967 P



12-7545



22974 P



22970 P

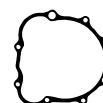

22972 P



22968 P



22969 P

9-609 - Kit O ring Completo

8-609 - Kit O ring Cabeza Cil.



12-012



12-012



12-013



12-114

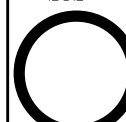

12-122



12-115



12-116

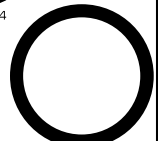

12-218



12-112



12-112



12-207



12-209

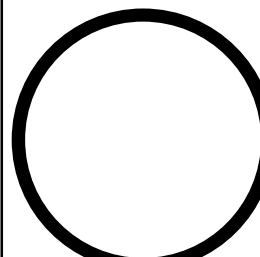

12-230



12-121



12-219

20147 P - BAJAJ 125 XCD (STREET)

Bases de Cil. ALMA METAL
incluidas en las líneas
PREMIUM y PREMIUM C/O RING

EQUIVALENTES

CODIGO	UNIDAD	MATERIAL
20147 P	JUEGO COMPLETO	PREMIUM
21147 P	CABEZA DE CILINDRO	PREMIUM
24001 A/M	BASE DE CILINDRO	ALMA METAL
24002 M	TAPA DE CILINDRO	METAL
24003	ESCAPE	CHAPA
24004 P	ADMISION	PREMIUM
24006 P	EMBRAGUE	PREMIUM
24007 P	CARTER	PREMIUM
24008 P	ENCENDIDO	PREMIUM
24005 P	TENSOR CADENA	PREMIUM

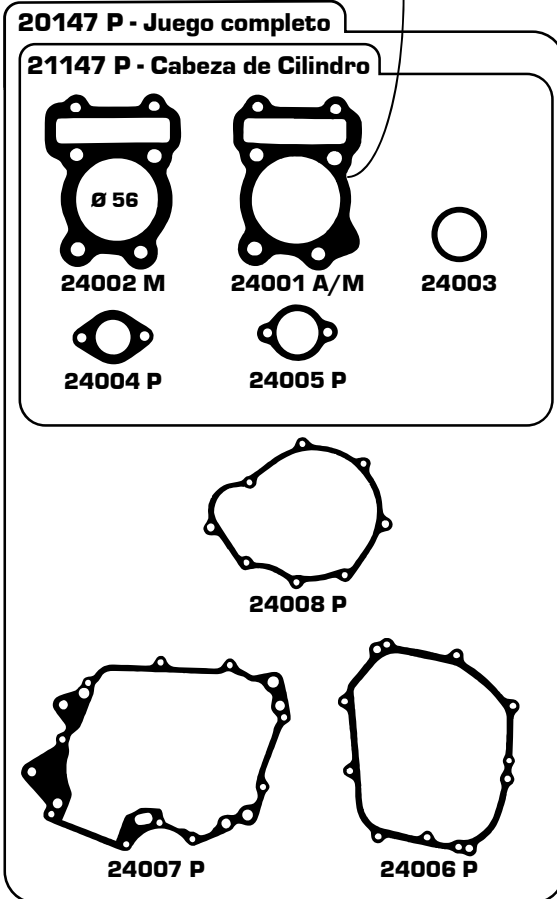



20146 P - BAJAJ 135 ROUSER

Bases de Cil. ALMA METAL
incluidas en las líneas
PREMIUM y PREMIUM C/O RING



EQUIVALENTES

EQUIVALENTES		

CODIGO	UNIDAD	MATERIAL
20146 P	JUEGO COMPLETO	PREMIUM C/T. VALV.
21146 P	CABEZA DE CILINDRO	PREMIUM C/T. VALV.
23993 A/M	BASE DE CILINDRO	ALMA METAL
23994 M	TAPA DE CILINDRO	METAL
23995	ESCAPE	CHAPA
23996 P	ADMISION	PREMIUM
23998 P	EMBRAGUE	PREMIUM
23999 P	CARTER	PREMIUM
24505 P	ENCENDIDO	PREMIUM
23997 P	TENSOR CADENA	PREMIUM
12-7756	TAPA VALVULAS	NITRILO

20146 P - Juego completo

21146 P - Cabeza de Cilindro



23994 M



23993 A/M



23995



23996 P



23997 P

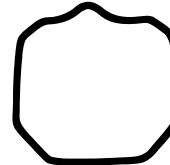

12-7756

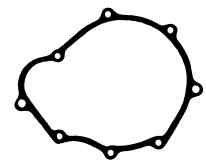

24505 P

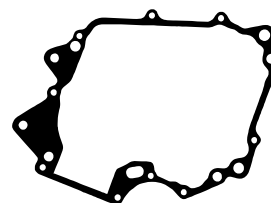

23999 P

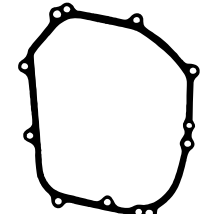

23998 P

20184 P - BAJAJ 150 ROUSER

Bases de Cil. ALMA METAL
incluidas en las líneas
PREMIUM y PREMIUM C/O RING



EQUIVALENTES

CODIGO	UNIDAD	MATERIAL
20184 P	JUEGO COMPLETO	PREMIUM
21184 P	CABEZA DE CILINDRO	PREMIUM
24016 A/M	BASE DE CILINDRO	ALMA METAL
24010 M	TAPA DE CILINDRO	METAL
24018	ESCAPE	CHAPA
24019 P	EMBRAGUE	PREMIUM
23967 P	CARTER A	PREMIUM
24020 P	CARTER B	PREMIUM
24021 P	ENCENDIDO	PREMIUM
24022 P	TENSOR CADENA	PREMIUM

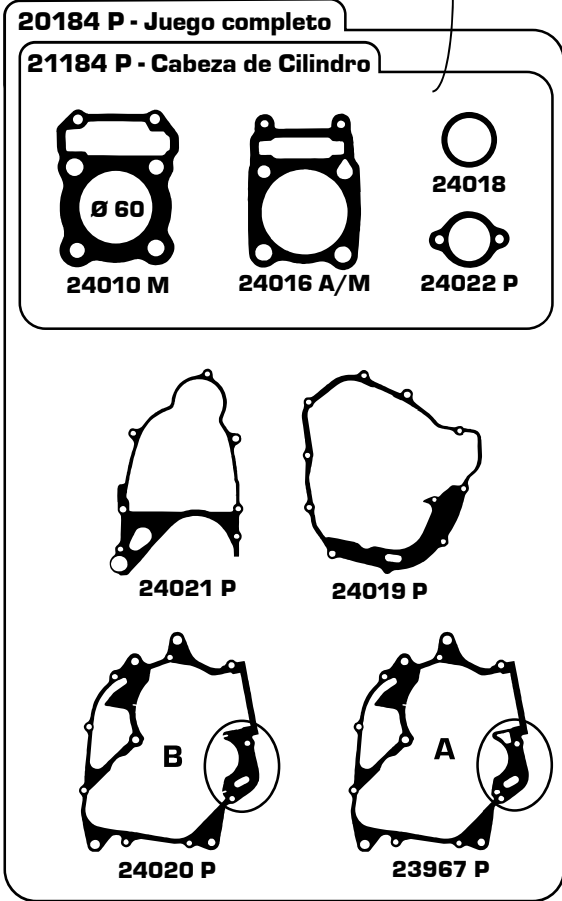

Motos y Cuatriciclos



20191 P - BAJAJ 180 ROUSER

Bases de Cil. ALMA METAL
incluidas en las líneas
PREMIUM y PREMIUM C/O RING



EQUIVALENTES	

CODIGO	UNIDAD	MATERIAL
20191 P	JUEGO COMPLETO	PREMIUM
21191 P	CABEZA DE CILINDRO	PREMIUM
24016 A/M	BASE DE CILINDRO	ALMA METAL
24424 M	TAPA DE CILINDRO	METAL
24018	ESCAPE	CHAPA
24019 P	EMBRAGUE	PREMIUM
23967 P	CARTER A	PREMIUM
24020 P	CARTER B	PREMIUM
24021 P	ENCENDIDO	PREMIUM
24022 P	TENSOR CADENA	PREMIUM

20191 P - Juego completo

21191 P - Cabeza de Cilindro



20149 P - BETA 200 MOTARD

Bases de Cil. ALMA METAL
incluidas en las líneas
PREMIUM y PREMIUM C/O'RING



EQUIVALENTES

BETA: TR 200 CROSS

CODIGO	UNIDAD	MATERIAL
20149 P	JUEGO COMPLETO	PREMIUM.
20149 P/O	JUEGO COMPLETO	PREMIUM C/O'RING
21149 P	CABEZA DE CILINDRO	PREMIUM
21149 P/O	CABEZA DE CILINDRO	PREMIUM C/O'RING
24429 A/M	BASE DE CILINDRO	ALMA METAL
24430 A	TAPA DE CILINDRO	MFT
24430 M	TAPA DE CILINDRO	METAL
24431	ESCAPE	CHAPA
24432 P	EMBRAGUE	PREMIUM
24433 P	ALTERNADOR	PREMIUM
24434 P	TENSOR CADENA	PREMIUM
9-647	KIT O'RING COMPLETO	NITRILO
8-647	KIT O'RING CABEZA CIL.	NITRILO

20149 P - Juego completo

21149 P - Cabeza de Cilindro

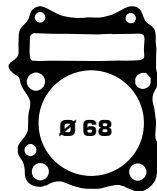

24430 A

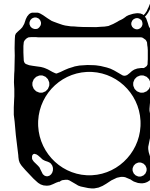

24429 A/M



24431



24434 P

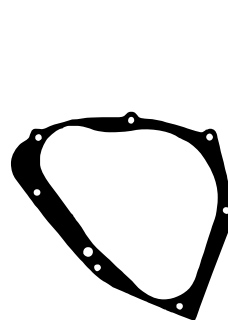

24433 P

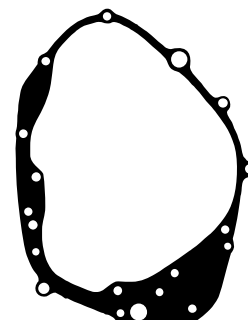

24432 P

9-647 - Kit O'ring Completo

8-647 - Kit O'ring Cabeza Cil.

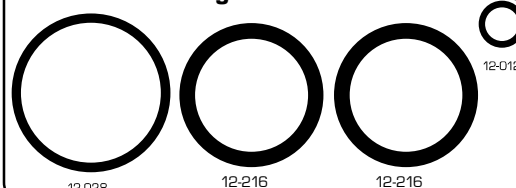

12-028

12-216

12-216

12-012

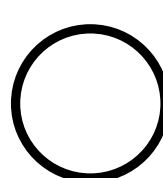

12-028



12-012

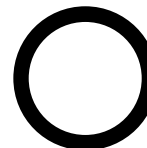

12-216

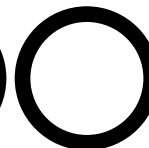

12-216

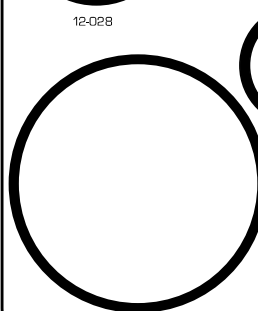

12-142



12-121

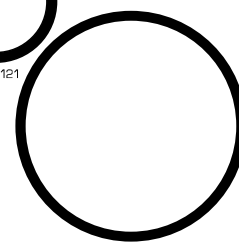

12-138



Motos y Cuatriciclos

06114 P - GILERA SMASH 110 (Ø 54 - CAD. 75 MM - P.A.RED.)

EQUIVALENTES	
APPIA:	ANDINA - CITI PLUS / BETA: BS - URBA
BRAVA:	ALPINA - APOLO - NEVADA / CORVEN: ENERGY - MIRAGE
DA-DALT:	DS / GILERA: C DLX - ESTILO - FUTURA - GLA
GUERRERO:	BIKE-FLASH-FUTURE-G DL-GN KEOKEN-GW WARRIOR-TRIP
HONDA:	BIZ 105 / IMSA: TRACK EVO / CERRO: BIX - FLY - LINK
KELLER:	BIG - CRONO CLASSIC - TITAN / KYMCO: ACTIV
KONISA:	MAGNIFICA - TUCUBIZ / MAVERICK: H / MONIDAL: LD
MOTOMEL:	BIT - C DLX - CLIPPER - FD
ZANELLA:	DUE - SEXY - SWING - VENTO 2V. - ZB 2V.

CODIGO	UNIDAD	MATERIAL
06114 P	JUEGO COMPLETO	PREMIUM
06114 P/O	JUEGO COMPLETO	PREMIUM C/O'RING
06369 P	CABEZA DE CILINDRO	PREMIUM
06369 P/O	CABEZA DE CILINDRO	PREMIUM C/O'RING
07846 A/M	BASE DE CILINDRO	ALMA METAL
07847 A	TAPA DE CILINDRO	MFT
07847 M	TAPA DE CILINDRO	METAL
07848	ESCAPE	CHAPA
07849 P	ADMISION AL CIL.	PREMIUM
07849 S	ADMISION AL CARB.	PREMIUM
07850 P	EMBRAGUE	PREMIUM
07851 P	CARTER	PREMIUM
07852	BOMBA ACEITE	ADAMITE
07853 P	ENCENDIDO	PREMIUM
07854 P	T/CABEZA DE CIL.	PREMIUM
07855 P	LAT. IZQ. CHICO	PREMIUM
06658 P	LAT. IZQ. GRANDE	PREMIUM
07856 P	LATERAL DERECHO	PREMIUM
07857	FILTRO ACEITE	ADAMITE
01538	FILTRO ACEITE	ADAMITE
07858 P	CENTRIFUGO	PREMIUM
01509 P	CENTRIFUGO	PREMIUM
9-605	KIT O'RING COMPLETO	NITRILO
8-605	KIT O'RING CABEZA CIL.	NITRILO
9-638	KIT O'RING TAPA CIL.	NITRILO

06114 P - Juego completo

Bases de Cil. ALMA METAL incluidas en las líneas PREMIUM y PREMIUM C/O'RING

06369 P - Cabeza de Cilindro

Metal Material Premium

07847 M **07846 A/M** **07849 P**
06658 P **07855 P** **07849 S**
07848 **07856 P** **07854 P**

01538 **07857** **07852** **07858 P** **01509 P**

07853 P **07850 P** **07851 P**

9-605 - Kit O'ring Completo

8-605 - Kit O'ring Cabeza Cil.

9-638 - Kit O'ring Tapa de Cil.

12-7485 **12-7486** **12-7487** **11-0303**

12-217 **12-217** **12-120**

12-113 **12-209**
12-010 **12-010**
12-046 **12-023**

20016 P - GILERA SMASH 110 (Ø 54 - CAD. 83 MM - P.A.RED.)

EQUIVALENTES

GUERRERO: FLASH 110 - TRIP 110

CODIGO	UNIDAD	MATERIAL
20016 P	JUEGO COMPLETO	PREMIUM
20016 P/O	JUEGO COMPLETO	PREMIUM C/O'RING
21014 P	CABEZA DE CILINDRO	PREMIUM
21014 P/O	CABEZA DE CILINDRO	PREMIUM C/O'RING
22286 A/M	BASE DE CILINDRO	ALMA METAL
22287 A	TAPA DE CILINDRO	MFT
22287 M	TAPA DE CILINDRO	METAL
22288	ESCAPE	CHAPA
22289 P	ADMISION AL CIL.	PREMIUM
22299 P	ADMISION AL CARB.	PREMIUM
22290 P	EMBRAGUE	PREMIUM
22291 P	CARTER	PREMIUM
22292	BOMBA ACEITE	ADAMITE
22293 P	ENCENDIDO	PREMIUM
22294 P	T/CABEZA DE CIL.	PREMIUM
22295 P	T/DISTRIBUCION	PREMIUM
22296 P	LATERAL DERECHO	PREMIUM
22297	FILTRO ACEITE	ADAMITE
07583	FILTRO ACEITE SMASH	ADAMITE
22298 P	CENTRIFUGO	PREMIUM
01509 P	CENTRIFUGO	PREMIUM
9-605	KIT O'RING COMPLETO	NITRILO
8-605	KIT O'RING CABEZA CIL.	NITRILO
9-638	KIT O'RING TAPA CIL.	NITRILO

20016 P - Juego completo

21014 P - Cabeza de Cilindro

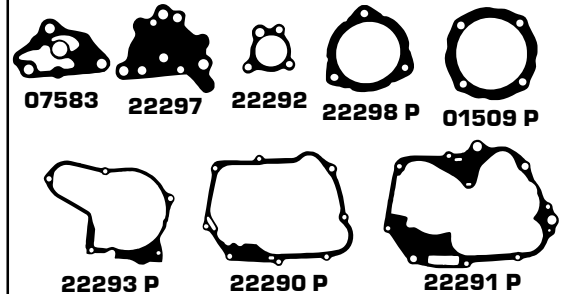
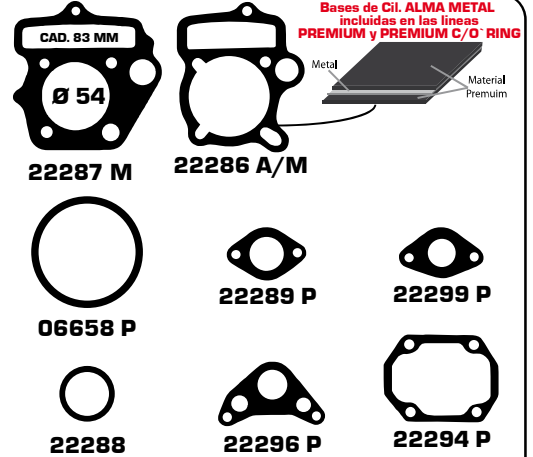

9-605 - Kit O'ring Completo

8-605 - Kit O'ring Cabeza Cil.

9-638 - Kit O'ring Tapa de Cil.

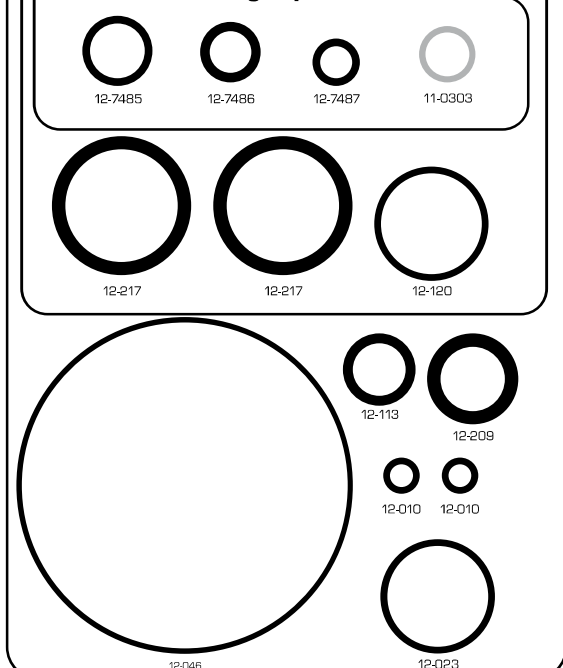

20076 P - GILERA SMASH 125 REVOLUTION (P.A.RED.)

EQUIVALENTES
APPIA: BERAKA 125 - GEREMY 125 / BRAVA: ATHENE 125
KELLER: CRONO TRIAL 125 / KONISA: CITIZEN 125 - KONITOP 125-KONISTAR
MAVERICK: SUPRA 125 / MONDIAL: LD 125
MOTOMEL: TOP 125 (CUBS) - BLITZ 125 - SKORPIO 125 / OKINOI: 125
ZANELLA: SEXY 125 - DUE 125

CODIGO	UNIDAD	MATERIAL
20076 P	JUEGO COMPLETO	PREMIUM
20076 P/O	JUEGO COMPLETO	PREMIUM C/O'RING
21078 P	CABEZA DE CILINDRO	PREMIUM
21078 P/O	CABEZA DE CILINDRO	PREMIUM C/O'RING
23564 A/M	BASE DE CILINDRO	ALMA METAL
23565 A	TAPA DE CILINDRO	MFT
23565 M	TAPA DE CILINDRO	METAL
23566	ESCAPE	CHAPA
23567 P	ADMISION AL CIL.	PREMIUM
23568 p	ADMISION AL CARB.	PREMIUM
23569 P	EMBRAGUE	PREMIUM
23570 P	CARTER	PREMIUM
23571	BOMBA ACEITE	ADAMITE
23572 P	ENCENDIDO	PREMIUM
23573 P	T/CABEZA DE CIL.	PREMIUM
23574 P	T/DISTRIBUCION	PREMIUM
23575 P	LATERAL DERECHO	PREMIUM
23576	FILTRO ACEITE	ADAMITE
07852	FILTRO ACEITE	ADAMITE
23577 P	CENTRIFUGO	PREMIUM
01509 P	CENTRIFUGO	PREMIUM
9-605	KIT O'RING COMPLETO	NITRILO
8-605	KIT O'RING CABEZA CIL.	NITRILO
9-638	KIT O'RING TAPA CIL.	NITRILO

20076 P - Juego completo

Bases de Cil. ALMA METAL incluidas en las líneas PREMIUM y PREMIUM C/O'RING

21078 P - Cabeza de Cilindro

23565 M 23564 A/M
 06658 P 23567 P 23568 S
 23566 23575 P 23574 P
 23576 07852 23571 23577 P 01509 P
 23572 P 23569 P 23570 P

9-605 - Kit O'ring Completo

8-605 - Kit O'ring Cabeza Cil.

9-638 - Kit O'ring Tapa de Cil.

12-7485 12-7486 12-7487 11-0303
 12-217 12-217 12-120
 12-113 12-209
 12-010 12-010
 12-046 12-023

06214 P - GILERA YL 150 (CUSTOM - BAL.)

Bases de Cil. ALMA METAL
incluidas en las líneas
PREMIUM y PREMIUM C/O'RING

EQUIVALENTES	
ZANELLA: RX 150 (BAL.)	

CODIGO	UNIDAD	MATERIAL
06214 P	JUEGO COMPLETO	PREMIUM C/T. VALV.
06214 P/O	JUEGO COMPLETO	PREM. C/O'RING Y T/V
06493 P	CABEZA DE CILINDRO	PREMIUM
06493 P/O	CABEZA DE CILINDRO	PREM. C/O'RING Y T/V
08934 A/M	BASE DE CILINDRO	ALMA METAL
08935 A	TAPA DE CILINDRO	MFT
08935 M	TAPA DE CILINDRO	METAL
08327	ESCAPE (2 X JGO.)	CHAPA
23011 P	ADMISION (2 X JGO.)	PREMIUM
08855 P	EMBRAGUE	PREMIUM
08856 P	CARTER	PREMIUM
23012	BOMBA ACEITE	ADAMITE
08936 P	ENCENDIDO IZQ.	PREMIUM
08938 P	CENTRIFUGO ACEITE	PREMIUM
12-7545	TAPA VÁLVULAS	NITRILO
9-642	KIT O'RING COMPLETO	NITRILO
8-642	KIT O'RING CABEZA CIL.	NITRILO

06214 P - Juego completo

06493 P - Cabeza de Cilindro



08935 M



08934 A/M



23011 P



23011 P



08327



08327

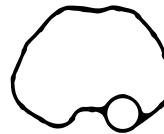

12-7545



08938 P



23012

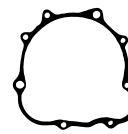

08936 P



08855 P

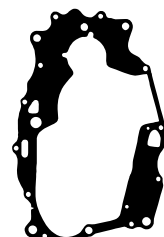

08856 P

9-642 - Kit O'ring Completo

8-642 - Kit O'ring Cabeza Cil.



12-012

12-012

12-013

12-114

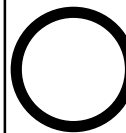

12-122



12-115



12-116

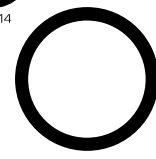

12-218



12-112



12-112



12-207



12-209

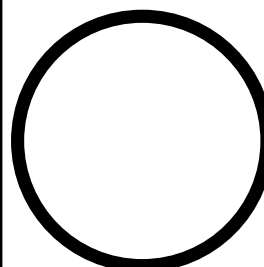

12-230



12-121



12-219

20021 P - GILERA SMX 200 (VAR. BAL. CORTO)

Bases de Cil. ALMA METAL
incluidas en las líneas
PREMIUM y PREMIUM C/O RING



EQUIVALENTES	
GILERA:	SAHEL 200 (VAR. BAL. CORTO) - VC 200 (VAR. BAL. CORTO)
GUERRERO:	TUNDRA GXR 200 (VAR. BAL. CORTO)
MOTOMEL:	SKUA 200 MOTARD (VAR. BAL. CORTO)

CODIGO	UNIDAD	MATERIAL
20021 P	JUEGO COMPLETO	PREMIUM C/T. VALV.
20021 P/O	JUEGO COMPLETO	PREM. C/O'RING Y T/V
21055 P	CABEZA DE CILINDRO	PREMIUM
21055 P/O	CABEZA DE CILINDRO	PREM. C/O'RING Y T/V
23197 A/M	BASE DE CILINDRO	ALMA METAL
23198 M	TAPA DE CILINDRO	METAL
23199	ESCAPE	CHAPA
23200 P	ADMISION (2 X JGO)	PREMIUM
23201 P	EMBRAGUE	PREMIUM
23202 P	CARTER	PREMIUM
23203	BOMBA ACEITE	ADAMITE
23205 P	ENCENDIDO IZQ.	PREMIUM
23207 P	T/CENT. ACEITE	PREMIUM
12-7545	TAPA VALVULAS	NITRILO
9-642	KIT O'RING COMPLETO	NITRILO
8-642	KIT O'RING CABEZA CIL.	NITRILO

20021 P - Juego completo

21055 P - Cabeza de Cilindro

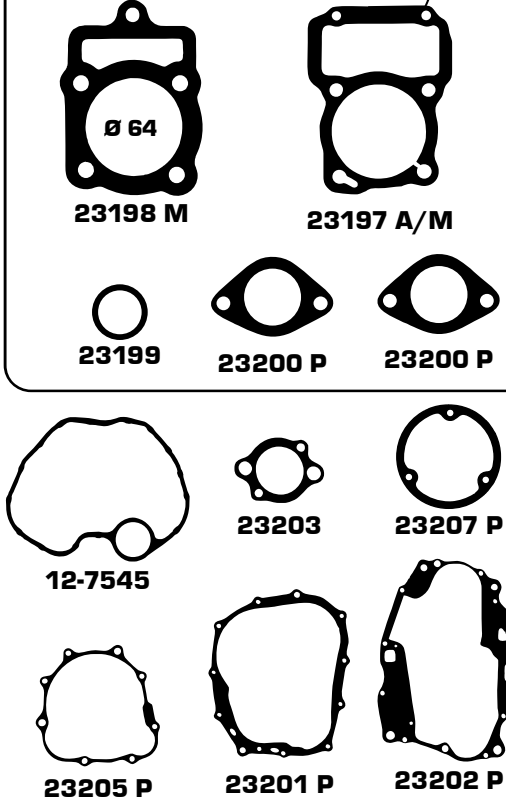

9-642 - Kit O'ring Completo

8-642 - Kit O'ring Cabeza Cil.

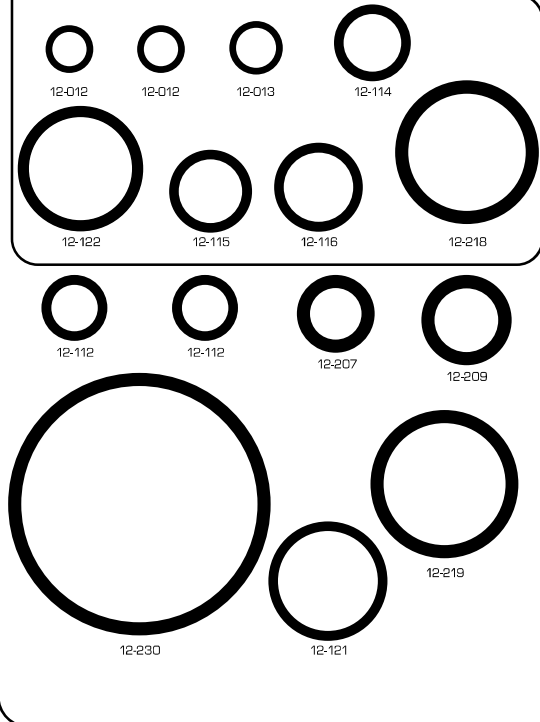

20258 P - GILERA VCR 200

Bases de Cil. ALMA METAL
incluidas en las líneas
PREMIUM y PREMIUM C/O'RING

EQUIVALENTES
MOTOMEL: SKUA 200 (CAD. BAL.) - SR 200 (CAD. BAL.)
TCP 200 (CAD. BAL.)

CODIGO	UNIDAD	MATERIAL
20258 P	JUEGO COMPLETO	PREMIUM
20258 P/O	JUEGO COMPLETO	PREMIUM C/O'RING
21258 P	CABEZA DE CILINDRO	PREMIUM
21258 P/O	CABEZA DE CILINDRO	PREMIUM C/O'RING
25273 A/M	BASE DE CILINDRO	ALMA METAL
25274 A	TAPA DE CILINDRO	MFT
25274 M	TAPA DE CILINDRO	METAL
25275	ESCAPE	CHAPA
25276 P	ADMISION (2 X JGO)	PREMIUM
25277 P	EMBRAGUE	PREMIUM
25278 P	CARTER	PREMIUM
25279	BOMBA ACEITE	ADAMITE
25280 P	ENCENDIDO IZQ.	PREMIUM
25283 P	T/CENT. ACEITE	PREMIUM
25282 P	ABOL DE LEVAS	PREMIUM
25281 P	TENSOR CADENA	PREMIUM
9-643	KIT O'RING COMPLETO	NITRILIO
8-643	KIT O'RING CABEZA CIL.	NITRILIO



20258 P - Juego completo

21258 P - Cabeza de Cilindro

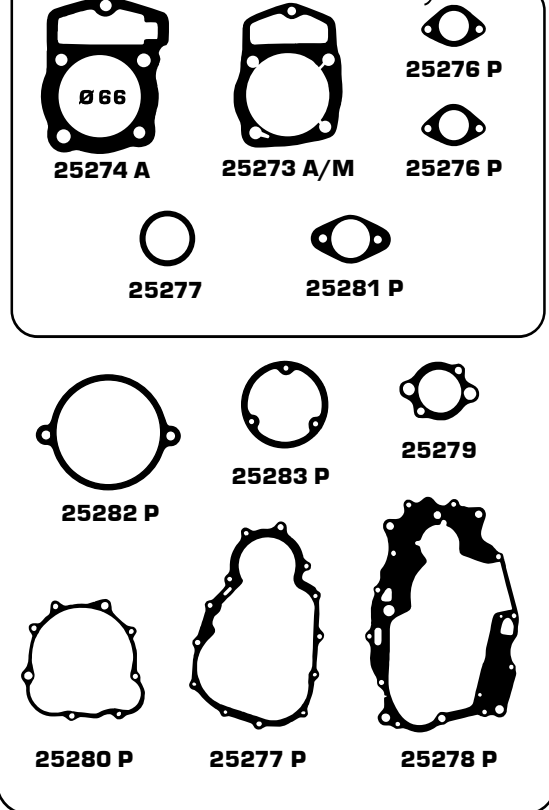

9-643 - Kit O ring Completo

8-643 - Kit O ring Cabeza Cil.

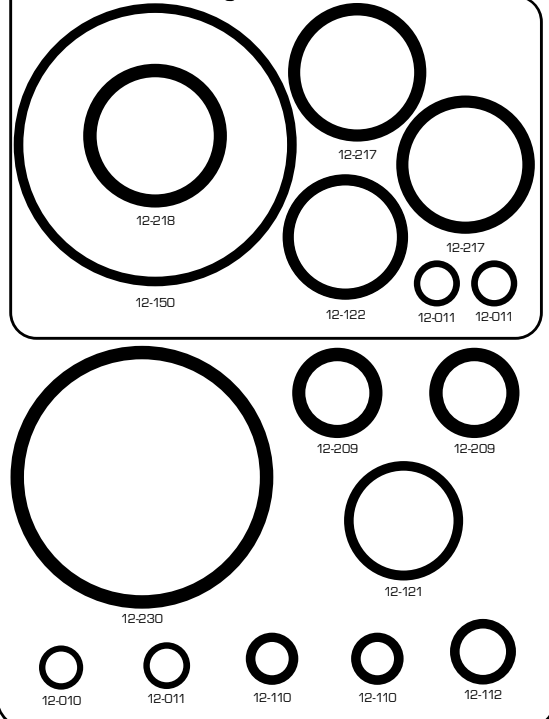

20287 P - GILERA SMX 400

Bases de Cil. ALMA METAL
incluidas en las líneas
PREMIUM y PREMIUM C/O RING

EQUIVALENTES		

CODIGO	UNIDAD	MATERIAL
20287 P	JUEGO COMPLETO	PREMIUM
21287 P	CABEZA DE CILINDRO	PREMIUM
24486 A/M	BASE DE CILINDRO	ALMA METAL
24487 M	TAPA DE CILINDRO	METAL
24488	ESCAPE	CHAPA
24489 P	EMBRAGUE	PREMIUM
24490 P	CARTER	PREMIUM
24494 P	ALTERNADOR	PREMIUM
24495 A/M	JUNTA CHICA	ALMA METAL



20287 P - Juego completo
21287 P - Cabeza de Cilindro

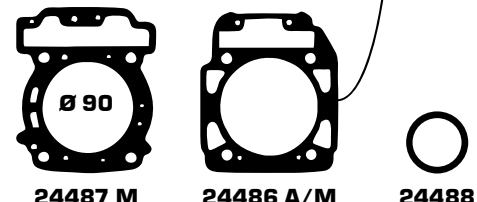

24487 M 24486 A/M 24488

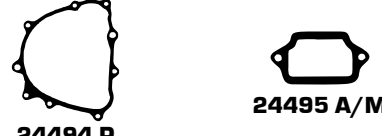

24494 P 24495 A/M

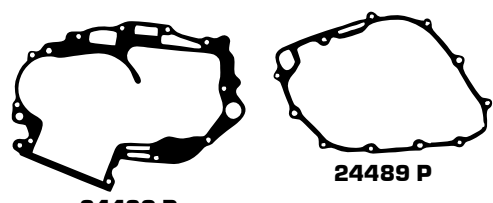

24490 P 24489 P

00354 P - GUERRERO G 70 (A/ELECT.)

EQUIVALENTES

GUERRERO: FUTURE 70

MOTOMEL: ECO A/E

ZANELLA: TRICARGO 70

CODIGO	UNIDAD	MATERIAL
00354 P	JUEGO COMPLETO	PREMIUM
00354 P/O	JUEGO COMPLETO	PREMIUM C/O'RING
00639 P	CABEZA DE CILINDRO	PREMIUM
00639 P/O	CABEZA DE CILINDRO	PREMIUM C/O'RING
22671 A/M	BASE DE CILINDRO	ALMA METAL
22672 A	TAPA DE CILINDRO	MFT
22672 M	TAPA DE CILINDRO	METAL
22673	ESCAPE	CHAPA
22674 P	ADMISION AL CIL.	PREMIUM
22683 P	ADMISION AL CARB.	PREMIUM
22675 P	EMBRAGUE	PREMIUM
22676 P	CARTER	PREMIUM
22677	BOMBA ACEITE	ADAMITE
02439 P	ENCENDIDO	PREMIUM
22678 P	T/CABEZA DE CIL.	PREMIUM
22679 P	T/DISTRIBUCION	PREMIUM
22680 P	LATERAL DERECHO	PREMIUM
22681	FILTRO ACEITE	ADAMITE
22682 P	CENTRIFUGO ACEITE	PREMIUM
9-605	KIT O'RING COMPLETO	NITRILO
8-605	KIT O'RING CABEZA CIL.	NITRILO
9-638	KIT O'RING TAPA CIL.	NITRILO

00354 P - Juego completo

00639 P - Cabeza de Cilindro

Bases de Cil. ALMA METAL incluidas en las líneas PREMIUM y PREMIUM C/O'RING

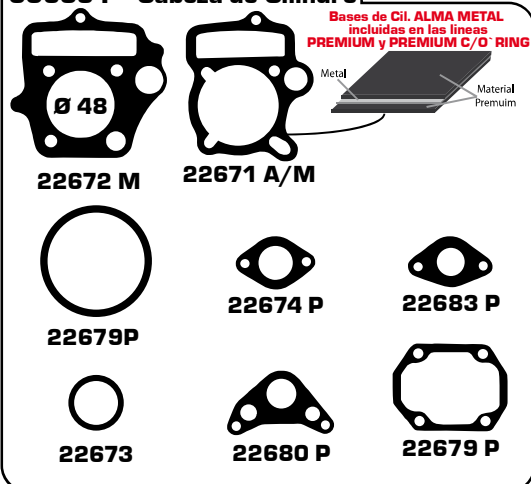

9-605 - Kit O'ring Completo

8-605 - Kit O'ring Cabeza Cil.

9-638 - Kit O'ring Tapa de Cil.

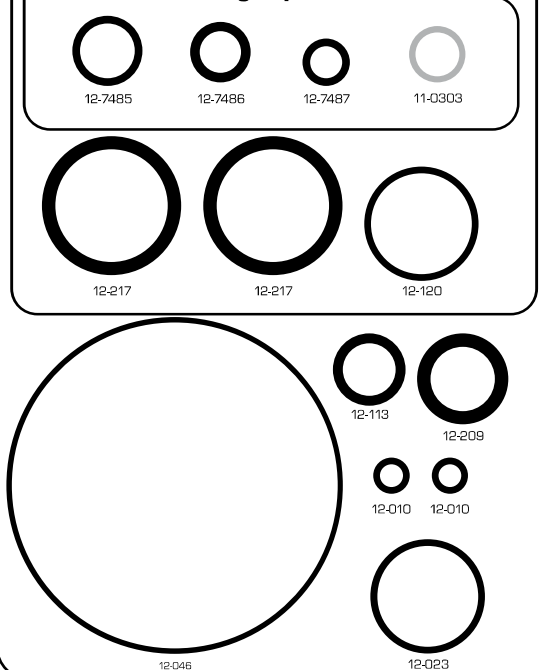

06021 P - G. TRIP 110 (Ø 54 - CAD. 83 MM - P.A.OVAL.)

EQUIVALENTES

APPIA: DCN 110 - VECTRA 110
 GILERA: SMASH 110 - FX 125 P.A.OVAL.
 GUERRERO: FLASH 110

CODIGO	UNIDAD	MATERIAL
06021 P	JUEGO COMPLETO	PREMIUM
06021 P/O	JUEGO COMPLETO	PREMIUM C/O'RING
06279 P	CABEZA DE CILINDRO	PREMIUM
06279 P/O	CABEZA DE CILINDRO	PREMIUM C/O'RING
06649 A/M	BASE DE CILINDRO	ALMA METAL
06650 A	TAPA DE CILINDRO	MFT
06650 M	TAPA DE CILINDRO	METAL
06651	ESCAPE	CHAPA
06652 P	ADMISION AL CIL.	PREMIUM
06652 S	ADMISION AL CARB.	PREMIUM
06653 P	EMBRAGUE	PREMIUM
06654 P	CARTER	PREMIUM
06655	BOMBA ACEITE	ADAMITE
06656 P	ENCENDIDO	PREMIUM
06657 P	T/CABEZA DE CIL.	PREMIUM
06658 P	T/DISTRIBUCION	PREMIUM
06659 P	LATERAL DERECHO	PREMIUM
06660	FILTRO ACEITE	ADAMITE
06661 P	CENTRIFUGO ACEITE	PREMIUM
9-605	KIT O'RING COMPLETO	NITRILO
8-605	KIT O'RING CABEZA CIL.	NITRILO
9-638	KIT O'RING TAPA CIL.	NITRILO

06021 P - Juego completo

06279 P - Cabeza de Cilindro

Bases de Cil. ALMA METAL incluidas en las líneas PREMIUM y PREMIUM C/O' RING

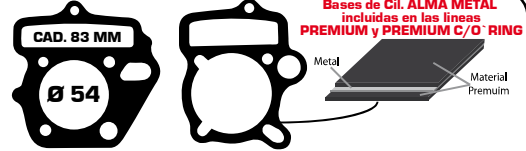

06650 M 06649 A/M

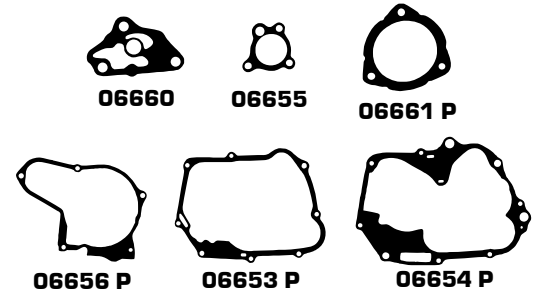
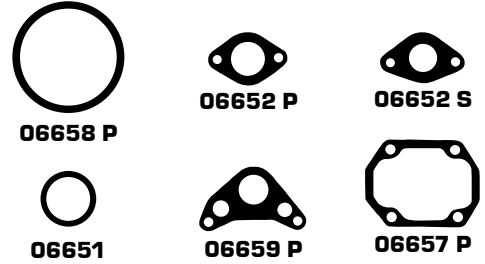

9-605 - Kit O'ring Completo

8-605 - Kit O'ring Cabeza Cil.

9-638 - Kit O'ring Tapa de Cil.

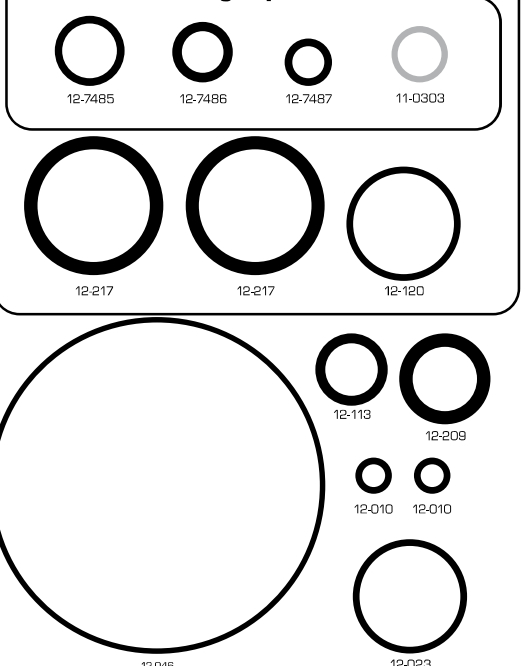



Bases de Cil. ALMA METAL
incluidas en las líneas
PREMIUM y PREMIUM C/O RING



00056 P - GUERRERO GMX 150 (CUSTOM)

EQUIVALENTES	
BETA:	BK 150
CERRO:	PRINCE 150 (CAD.)
KAYAK:	150
MOTOMEL:	CUSTOM 150 (CAD.)

CODIGO	UNIDAD	MATERIAL
00056 P	JUEGO COMPLETO	PREMIUM
00056 P/O	JUEGO COMPLETO	PREMIUM C/O RING
00678 P	CABEZA DE CILINDRO	PREMIUM
00678 P/O	CABEZA DE CILINDRO	PREMIUM C/O RING
01327 A/M	BASE DE CILINDRO	ALMA METAL
01328 A	TAPA DE CILINDRO	MFT
01328 M	TAPA DE CILINDRO	METAL
01329	ESCAPE	CHAPA
02025 P	TENSOR CADENA	PREMIUM
01330 P	EMBRAGUE	PREMIUM
01331 P	CARTER	PREMIUM
01332 P	ENCENDIDO CHICO	PREMIUM
01333 P	ENCENDIDO IZQ.	PREMIUM
01348 P	ARBOL DE LEVAS	PREMIUM
01334 P	CENTRIFUGO ACEITE	PREMIUM
01349	BOMBA ACEITE	ADAMITE
9-643	KIT O RING COMPLETO	NITRILO
8-643	KIT O RING CABEZA CIL.	NITRILO

00056 P - Juego completo

00678 P - Cabeza de Cilindro

9-643 - Kit O ring Completo

8-643 - Kit O ring Cabeza Cil.

20452 P - GUERRERO GR1 200

Bases de Cil. ALMA METAL
incluidas en las líneas
PREMIUM y PREMIUM C/O'RING



EQUIVALENTES	
GUERRERO: GR5 230	

CODIGO	UNIDAD	MATERIAL
20452 P	JUEGO COMPLETO	PREMIUM
20452 P/O	JUEGO COMPLETO	PREMIUM C/O'RING
21452 P	CABEZA DE CILINDRO	PREMIUM
21452 P/O	CABEZA DE CILINDRO	PREMIUM C/O'RING
25386 A/M	BASE DE CILINDRO	ALMA METAL
25387 M	TAPA DE CILINDRO	METAL
25388	ESCAPE	CHAPA
25389 P	ADMISION	PREMIUM
25390 M	TENSOR CADENA	METAL
25391 P	T/CENT. ACEITE	PREMIUM
25392 P	T/ARBOL DE LEVAS	PREMIUM
25393 P	EMBRAQUE	PREMIUM
25394 P	ENCENDIDO	PREMIUM
25395 P	CARTER	PREMIUM
9-648	KIT O'RING COMPLETO	NITRILO
8-648	KIT O'RING CAB. CIL.	NITRILO

20452 P - Juego Completo

21452 P - Cabeza de Cilindro

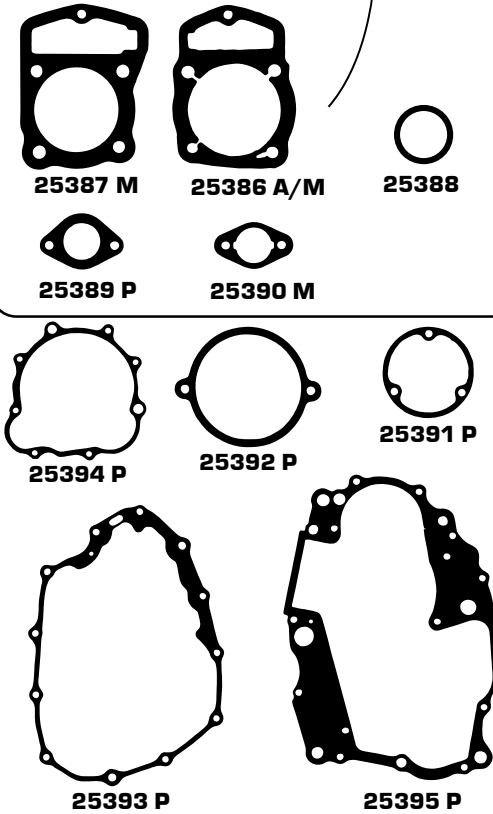

9-648 - Kit O'ring Completo

8-648 - Kit O'ring Cabeza Cil.

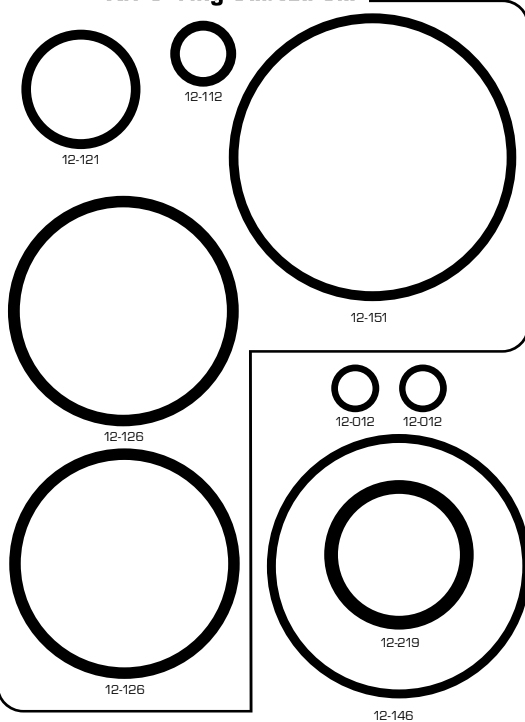



Bases de Cil. ALMA METAL
incluidas en las líneas
PREMIUM y PREMIUM C/O' RING

20027 P - GUERRERO 200 TUNDRA (BAL.)



EQUIVALENTES

GILERA: SAHER 200 (VAR.BAL.LARGO)- SMX 200 (VAR.BAL.LARGO)
GUERRERO: GMX 200 MOTARD (BAL.)
MAVERICK: DUAL 200 MOTARD (BAL.) / **MONDIAL:** TD 200
MOTOMEL: DAKAR 200 / **ZANELLA:** RX 200 NAKED

CODIGO	UNIDAD	MATERIAL
20027 P	JUEGO COMPLETO	PREMIUM C/T. VALV.
20027 P/O	JUEGO COMPLETO	PREM. C/O'RING Y T/V
21044 P	CABEZA DE CILINDRO	PREMIUM
21044 P/O	CABEZA DE CILINDRO	PREM. C/O'RING Y T/V
23024 A/M	BASE DE CILINDRO	ALMA METAL
23025 M	TAPA DE CILINDRO	METAL
23026	ESCAPE	CHAPA
23027 P	ADMISION (2 X JGO)	PREMIUM
23028 P	EMBRAGUE	PREMIUM
23029 P	CARTER	PREMIUM
23030	BOMBA ACEITE	ADAMITE
23032 P	ENCENDIDO IZQ.	PREMIUM
23034 P	CENTRIFUGO ACEITE	PREMIUM
12-7545	TAPA DE VÁLVULAS	NITRILO
9-642	KIT O'RING COMPLETO	NITRILO
8-642	KIT O'RING CABEZA CIL.	NITRILO

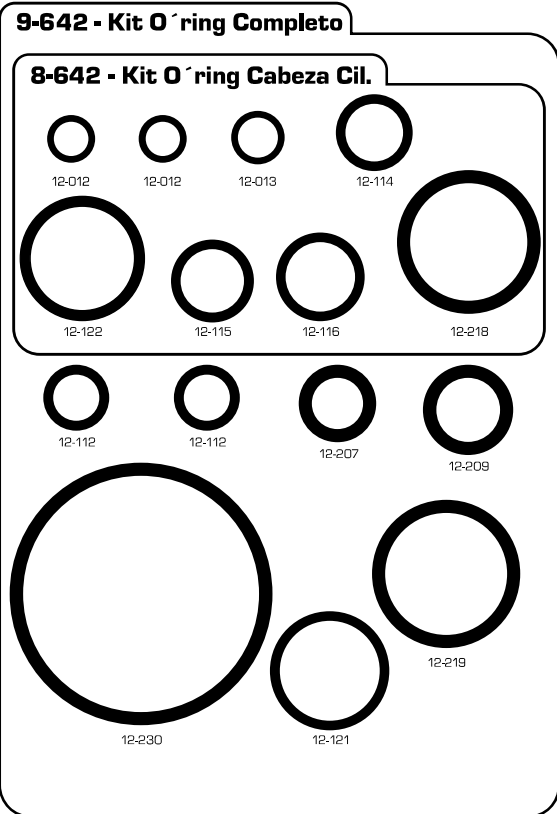
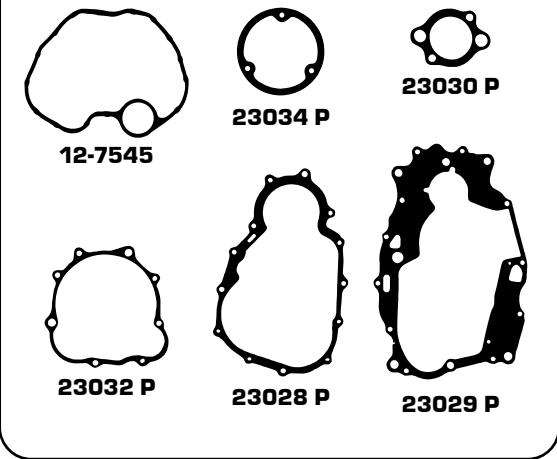
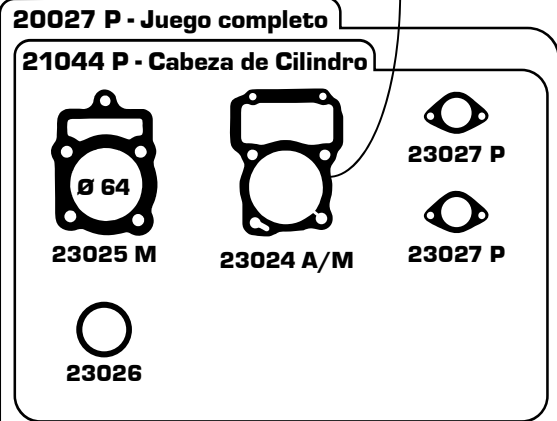



Motos y Cuatriciclos

Bases de Cil. ALMA METAL incluidas en las lineas PREMIUM



20387 P - GUERRERO 250 GRF (M. 2012)

EQUIVALENTES

CORVEN: TOURING 250
MOTOMEL: MEGELLI 250 (CAD.)
KAYAC: 250

CODIGO	UNIDAD	MATERIAL
20387 P	JUEGO COMPLETO	PREMIUM
21387 P	CABEZA DE CILINDRO	PREMIUM
25284 A/M	BASE DE CILINDRO	ALMA METAL
25285 A	TAPA DE CILINDRO	MFT C/FDO COBRE
25289 P	EMBRAGUE	PREMIUM
25290 P	ALTERNADOR	PREMIUM
25288 P	ENCENDIDO CHICO IZQ.	PREMIUM
25287 P	BOMBA DE AGUA	PREMIUM

20387 P - Juego Completo

21387 P - Cabeza de Cilindro

25285 A 25284 A/M

25288 P 25287 P

25290 P 25289 P

00101 P - HONDA BIZ C 100

EQUIVALENTES
HONDA: WAVE 100 NF - POP 100
GUERRERO: GD 100

CODIGO	UNIDAD	MATERIAL
00101 P	JUEGO COMPLETO	PREMIUM
00101 P/O	JUEGO COMPLETO	PREMIUM C/O'RING
00554 P	CABEZA DE CILINDRO	PREMIUM
00554 P/O	CABEZA DE CILINDRO	PREMIUM C/O'RING
01532 A/M	BASE DE CILINDRO	ALMA METAL
01533 A	TAPA DE CILINDRO	MFT
01533 M	TAPA DE CILINDRO	METAL
01534	ESCAPE	CHAPA
01535 P	ADMISION AL CIL.	PREMIUM
01535 S	ADMISION AL CARB.	PREMIUM
01536 P	EMBRAGUE	PREMIUM
01537 P	CARTER	PREMIUM
01538	BOMBA ACEITE	ADAMITE
01539 P	ENCENDIDO	PREMIUM
01558 P	T/CABEZA DE CIL.	PREMIUM
01559 P	T/DISTRIBUCION	PREMIUM
01560 P	LATERAL DERECHO	PREMIUM
01561	FILTRO ACEITE	ADAMITE
01557 P	CENTRIFUGO ACEITE	PREMIUM
9-605	KIT O'RING COMPLETO	NITRILO
8-605	KIT O'RING CABEZA CIL.	NITRILO
9-638	KIT O'RING TAPA CIL.	NITRILO

00101 P - Juego completo

00554 P - Cabeza de Cilindro

Bases de Cil. ALMA METAL
incluidas en las líneas
PREMIUM y PREMIUM C/O'RING

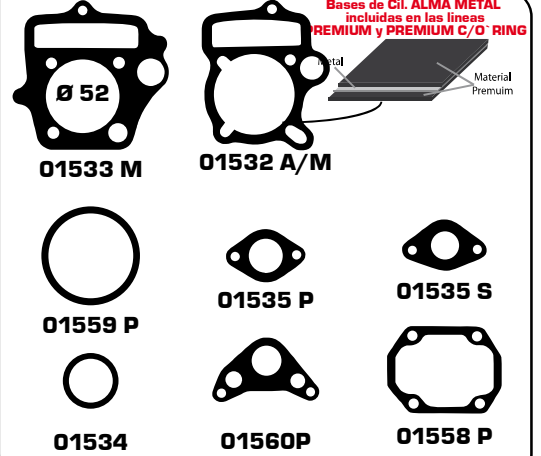

9-605 - Kit O'ring Completo

8-605 - Kit O'ring Cabeza Cil.

9-638 - Kit O'ring Tapa de Cil.

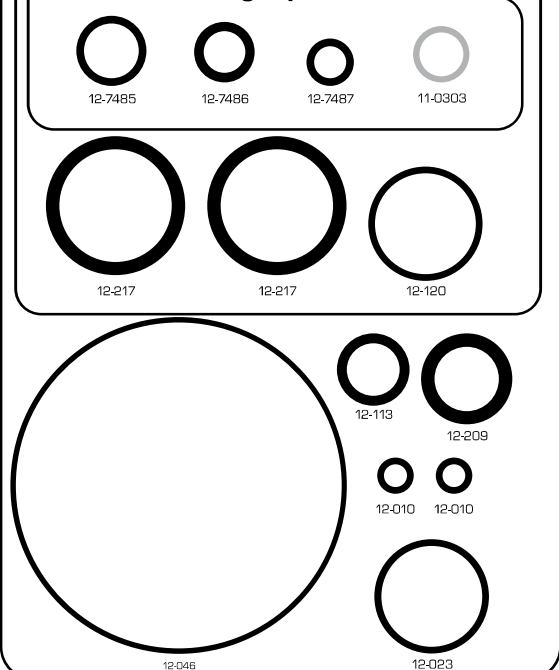

00109 P - HONDA HERO CD 100

EQUIVALENTES
GILERA: QM 100 - 9
GUERRERO: G 100 - WG BIKE 100
NANFANG: JIMNA FN 100

CODIGO	UNIDAD	MATERIAL
00109 P	JUEGO COMPLETO	PREMIUM
00109 P/O	JUEGO COMPLETO	PREMIUM C/O'RING
00567 P	CABEZA DE CILINDRO	PREMIUM
00567 P/O	CABEZA DE CILINDRO	PREMIUM C/O'RING
01562 A/M	BASE DE CILINDRO	ALMA METAL
01563 A	TAPA DE CILINDRO	MFT
01563 M	TAPA DE CILINDRO	METAL
01564	ESCAPE	CHAPA
01565 P	ADMISION AL CIL.	PREMIUM
01565 S	ADMISION AL CARB.	PREMIUM
01566 P	EMBRAGUE	PREMIUM
01567 P	CARTER	PREMIUM
01569	BOMBA ACEITE	ADAMITE
01570 P	ENCENDIDO	PREMIUM
01568 P	T/CABEZA DE CIL.	PREMIUM
01571 P	T/DISTRIBUCION	PREMIUM
01572 P	LATERAL DERECHO	PREMIUM
01573	FILTRO ACEITE	ADAMITE
01509 P	CENTRIFUGO ACEITE	PREMIUM
9-605	KIT O'RING COMPLETO	NITRILO
8-605	KIT O'RING CABEZA CIL.	NITRILO
9-638	KIT O'RING TAPA CIL.	NITRILO

00109 P - Juego completo

00567 P - Cabeza de Cilindro

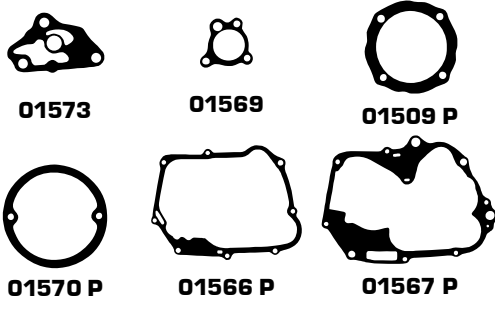
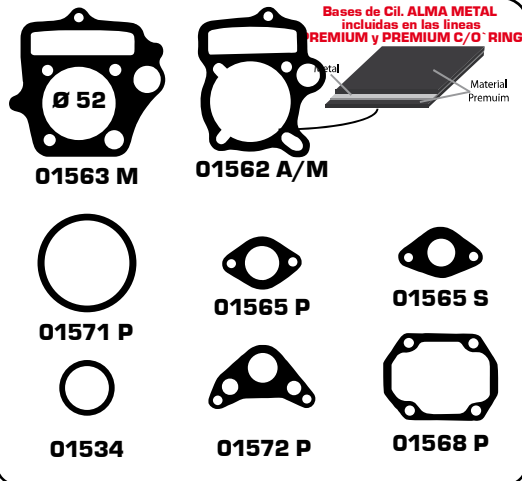

9-605 - Kit O'ring Completo

8-605 - Kit O'ring Cabeza Cil.

9-638 - Kit O'ring Tapa de Cil.

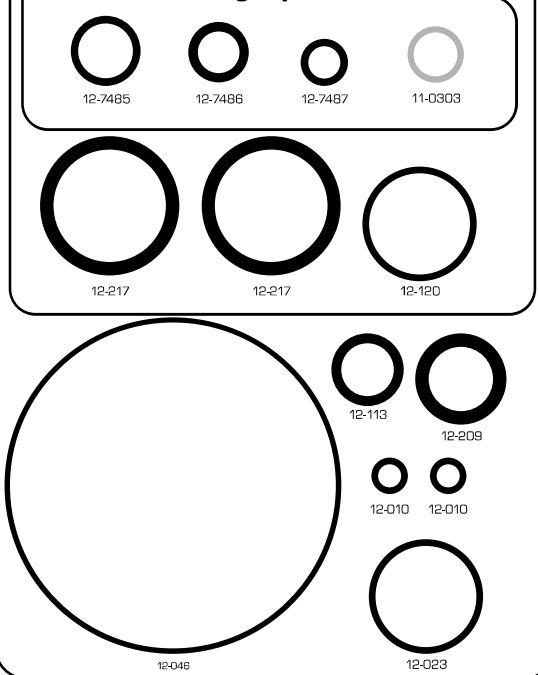

20310 P - HONDA WAVE 110

Bases de Cil. ALMA METAL
incluidas en las líneas PREMIUM



EQUIVALENTES

CODIGO	UNIDAD	MATERIAL
20310 P	JUEGO COMPLETO	PREMIUM
21310 P	CABEZA DE CILINDRO	PREMIUM
25000 A/M	BASE DE CILINDRO	ALMA METAL
25001 A	TAPA DE CILINDRO	MFT
25001 M	TAPA DE CILINDRO	METAL
25002	ESCAPE	CHAPA
25003 P	TENSOR CADENA	PREMIUM
25004 P	CENTRIFUGO ACEITE	PREMIUM
25005 P	EMBRAGUE	PREMIUM
25006 P	ENCENDIDO	PREMIUM
25007 P	CARTER	PREMIUM
12-7755	TAPA DE VÁLVULAS	NITRILLO

20310 P - Juego completo

21310 P - Cabeza de Cilindro

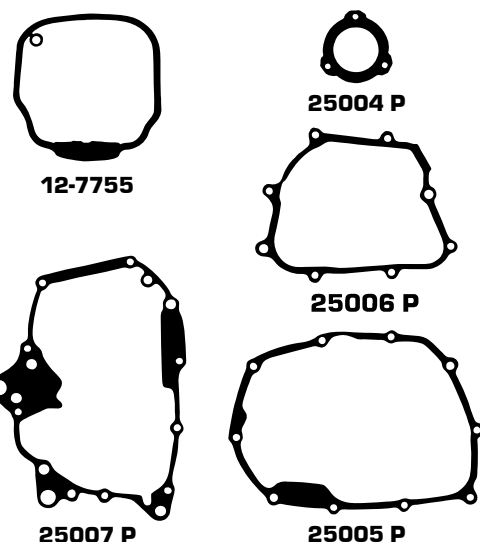
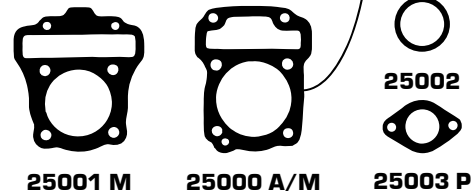

20344 P - HONDA CB1 125

Bases de Cil. ALMA METAL
incluidas en las líneas PREMIUM

EQUIVALENTES

CODIGO	UNIDAD	MATERIAL
20344 P	JUEGO COMPLETO	PREMIUM C/T. VALV.
21344 P	CABEZA DE CILINDRO	PREMIUM C/T. VALV.
25130 A/M	BASE DE CILINDRO	ALMA METAL
25131 M	TAPA DE CILINDRO	METAL
25132	ESCAPE	CHAPA
25133 P	ADMISION	PREMIUM
25134 P	COMPENSACION	PREMIUM
25135 P	BOMBA ACEITE	PREMIUM
25136 P	EMBRAGUE	PREMIUM
25137 P	ALTERNADOR	PREMIUM
25138 P	CARTER	PREMIUM
12-7594	T/DISTRIBUCION	NITRILO
12-7754	TAPA DE VÁLVULAS	NITRILO



20344 P - Juego completo

21344 P - Cabeza de Cilindro

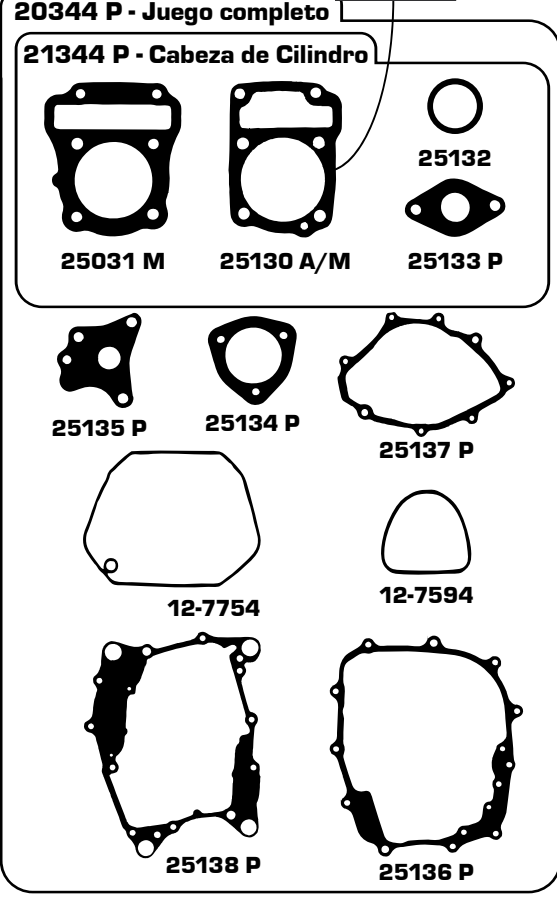

25031 M 25130 A/M 25132
25133 P

25135 P 25134 P 25137 P

12-7754 12-7594

25138 P 25136 P



20117 P - HONDA BIZ KS/ES 125 M. 2005

Bases de Cil. ALMA METAL
incluidas en las líneas
PREMIUM y PREMIUM C/O´RING

EQUIVALENTES	

CODIGO	UNIDAD	MATERIAL
20117 P	JUEGO COMPLETO	PREMIUM
20117 P/O	JUEGO COMPLETO	PREMIUM C/O´RING
21119 P	CABEZA DE CILINDRO	PREMIUM
21119 P/O	CABEZA DE CILINDRO	PREMIUM C/O´RING
23946 A/M	BASE DE CILINDRO	ALMA METAL
23947 A	TAPA DE CILINDRO	MFT
23947 M	TAPA DE CILINDRO	METAL
23948	ESCAPE	CHAPA
23966 P	ADMISION AL CIL.	PREMIUM
23950 P	EMBRAGUE	PREMIUM
23951 P	CARTER	PREMIUM
23953 P	ENCENDIDO	PREMIUM
23954 P	T/DISTRIBUCION	PREMIUM
23952 P	JUNTA CHICA	PREMIUM
8-636	KIT O´RING COMPLETO	NITRILO
9-636	KIT O´RING CABEZA CIL.	NITRILO

20117 P - Juego completo

21119 P - Cabeza de Cilindro

9-636 - Kit O´ring Completo

8-636 - Kit O´ring Cabeza Cil.



06171 P - HONDA STORM 125

Bases de Cil. ALMA METAL
incluidas en las líneas
PREMIUM y PREMIUM C/O RING



EQUIVALENTES

HONDA: XR 125 MOD. 2012

CODIGO	UNIDAD	MATERIAL
06171 P	JUEGO COMPLETO	PREMIUM C/T. VALV.
06171 P/O	JUEGO COMPLETO	PREM. C/O'RING Y T/V
06447 P	CABEZA DE CILINDRO	PREMIUM
06447 P/O	CABEZA DE CILINDRO	PREM. C/O'RING Y T/V
08866 A/M	BASE DE CILINDRO	ALMA METAL
23046 M	TAPA DE CILINDRO	METAL
23047	ESCAPE	CHAPA
23048 P	ADMISION	PREMIUM
23049 P	CARTER	PREMIUM
08867 P	EMBRAGUE	PREMIUM
23050	BOMBA ACEITE	ADAMITE
08868 P	ENCENDIDO IZQ.	PREMIUM
23053 P	T/CENT. ACEITE	PREMIUM
12-7545	TAPA VALVULAS	NITRILO
9-642	KIT O'RING COMPLETO	NITRILO
8-642	KIT O'RING CABEZA CIL.	NITRILO

06171 P - Juego completo

06447 P - Cabeza de Cilindro

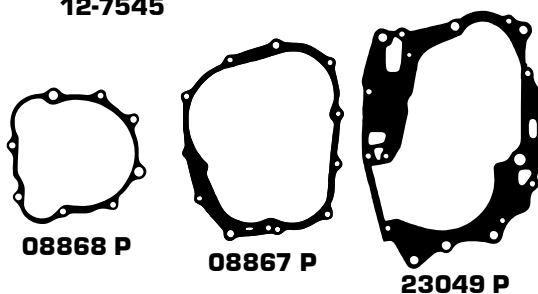
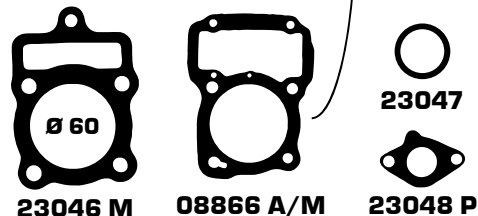

9-642 - Kit O'ring Completo

8-642 - Kit O'ring Cabeza Cil.

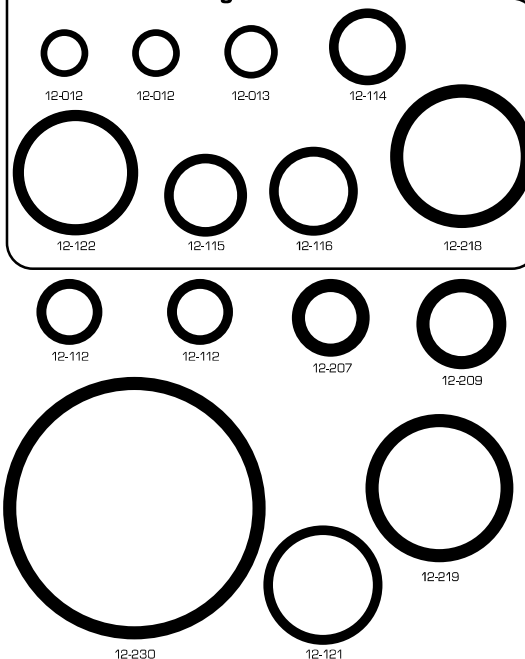

00121 P - HONDA TODAY 125

Bases de Cil. ALMA METAL
incluidas en las líneas
PREMIUM y PREMIUM C/O RING



EQUIVALENTES	
HONDA:	XLR 125
GILERA:	GA 125
GUERRERO:	GC 125
KYMCO:	SECTOR 125

CODIGO	UNIDAD	MATERIAL
00121 P	JUEGO COMPLETO	PREMIUM C/T. VALV.
00121 P/O	JUEGO COMPLETO	PREM. C/O'RING Y T/V
00578 P	CABEZA DE CILINDRO	PREMIUM
00578 P/O	CABEZA DE CILINDRO	PREM. C/O'RING Y T/V
06690 A/M	BASE DE CILINDRO	ALMA METAL
06691 A	TAPA DE CILINDRO	MFT
00692	ESCAPE	CHAPA
06693 P	ADMISION (2 X JGO)	PREMIUM
06694 P	EMBRAGUE	PREMIUM
06695 P	CARTER	PREMIUM
06697	BOMBA ACEITE	ADAMITE
06699 P	ENCENDIDO IZQ.	PREMIUM
06696 P	T/CENT. ACEITE	PREMIUM
12-7545	TAPA DE VÁLVULAS	NITRILO
9-641	KIT O'RING COMPLETO	NITRILO
8-641	KIT O'RING CABEZA CIL.	NITRILO

00121 P - Juego completo

00578 P - Cabeza de Cilindro



06691 A



06690 A/M



06692



06693 P



06693 P

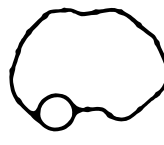

12-7545



06696 P



06697



06699 P

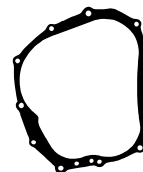

06694 P



06695 P

9-641 - Kit O'ring Completo

8-641 - Kit O'ring Cabeza Cil.



12-011



12-117

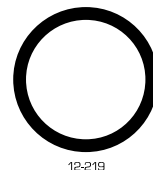

12-219



12-012



12-012



12-207



12-209



12-115

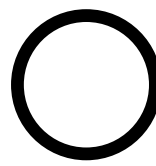

12-220

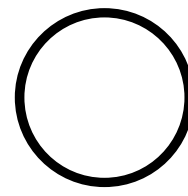

12-132

20311 P - HONDA XR 125 L M. 2013

Bases de Cil. ALMA METAL
incluidas en las líneas
PREMIUM y PREMIUM C/O'RING



EQUIVALENTES

HONDA: XR 125 L M.2013

CODIGO	UNIDAD	MATERIAL
20311 P	JUEGO COMPLETO	PREMIUM C/T. VALV.
20311 P/O	JUEGO COMPLETO	PREM. C/O'RING Y T/V
21311 P	CABEZA DE CILINDRO	PREMIUM
21311 P/O	CABEZA DE CILINDRO	PREM. C/O'RING Y T/V
08152 A/M	BASE DE CILINDRO	ALMA METAL
25128 M	TAPA DE CILINDRO	METAL
25128 A	TAPA DE CILINDRO	MFT
08154	ESCAPE	CHAPA
06693 P	ADMISION (2 X JGO)	PREMIUM
08155 P	EMBRAGUE	PREMIUM
08156 P	CARTER	PREMIUM
08157 P	ENCENDIDO	PREMIUM
08158 M	TENSOR CADENA	METAL
08159 P	T/CENT. ACEITE	PREMIUM
12-7650	TAPA DE VÁLVULAS	NITRILO
9-631	KIT O'RING COMPLETO	NITRILO
8-631	KIT O'RING CABEZA CIL.	NITRILO

20311 P - Juego completo

21311 P - Cabeza de Cilindro



25128 M

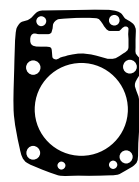

08152 A/M



08154



06693 P



06693 P



08158 M



08159 P

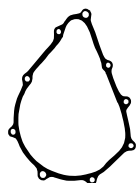

08157 P

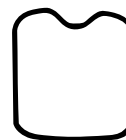

12-7650



08156 P

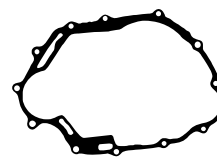

08155 P

9-631 - Kit O'ring Completo

8-631 - Kit O'ring Cabeza Cil.



12-012

12-012

12-013

12-114

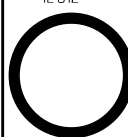

12-122



12-115

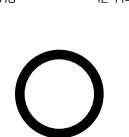

12-116

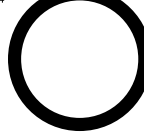

12-218



12-112



12-112



12-207



12-209

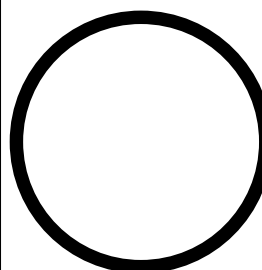

12-230



12-121



12-219

06141 P - HONDA CG 150 TITAN

Bases de Cil. ALMA METAL
incluidas en las líneas
PREMIUM y PREMIUM C/O RING



EQUIVALENTES	
APPIA:	BREZZA EURO 150
HONDA:	INVICTA CB 150 - XR 150

CODIGO	UNIDAD	MATERIAL
06141 P	JUEGO COMPLETO	PREMIUM C/T. VALV.
06141 P/O	JUEGO COMPLETO	PREM. C/O'RING Y T/V
06417 P	CABEZA DE CILINDRO	PREMIUM
06417 P/O	CABEZA DE CILINDRO	PREM. C/O'RING Y T/V
08152 A/M	BASE DE CILINDRO	ALMA METAL
08153 M	TAPA DE CILINDRO	METAL
08153 A	TAPA DE CILINDRO	MFT
08154	ESCAPE	CHAPA
06693 P	ADMISION (2 X JGO)	PREMIUM
08155 P	EMBRAGUE	PREMIUM
08156 P	CARTER	PREMIUM
08157 P	ENCENDIDO	PREMIUM
08158 M	TENSOR CADENA	METAL
08159 P	T/CENT. ACEITE	PREMIUM
12-7650	TAPA DE VÁLVULAS	NITRILO
9-631	KIT O'RING COMPLETO	NITRILO
8-631	KIT O'RING CABEZA CIL.	NITRILO

06141 P - Juego completo

06417 P - Cabeza de Cilindro

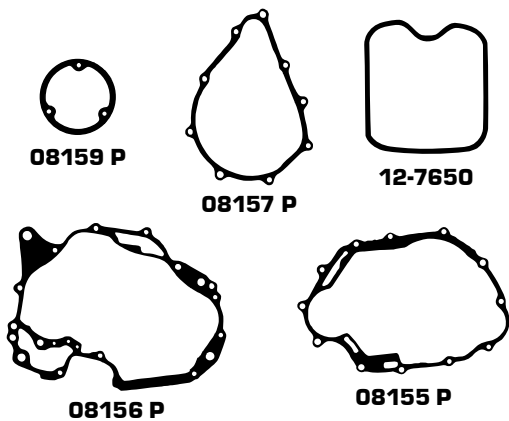
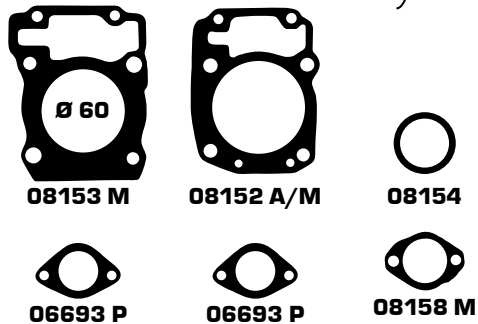

9-631 - Kit O ring Completo

8-631 - Kit O ring Cabeza Cil.

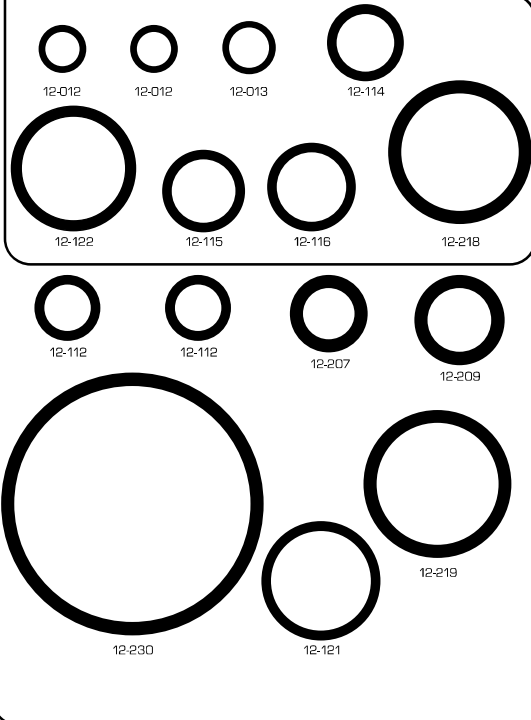

00127 P - HONDA NX 150

Bases de Cil. ALMA METAL
incluidas en las líneas
PREMIUM y PREMIUM C/O'RING



EQUIVALENTES	
HONDA:	AERO CBX 150
ZANELLA:	RX 150 (CAD.)

CODIGO	UNIDAD	MATERIAL
00127 P	JUEGO COMPLETO	PREMIUM
00127 P/O	JUEGO COMPLETO	PREMIUM C/O'RING
00586 P	CABEZA DE CILINDRO	PREMIUM
00586 P/O	CABEZA DE CILINDRO	PREMIUM C/O'RING
01706 A/M	BASE DE CILINDRO	ALMA METAL
01707 A	TAPA DE CILINDRO	MFT
01707 M	TAPA DE CILINDRO	METAL
01644	ESCAPE	CHAPA
02025 P	TENSOR CADENA	PREMIUM
01645 P	EMBRAGUE	PREMIUM
01646 P	CARTER	PREMIUM
01639 P	ENCENDIDO CHICO	PREMIUM
01647 P	ENCENDIDO IZQ.	PREMIUM
01641 P	ARBOL DE LEVAS	PREMIUM
01640 P	T/CENT. ACEITE	PREMIUM
23307	BOMBA ACEITE	ADAMITE
9-614	KIT O'RING COMPLETO	NITRILO
8-614	KIT O'RING CABEZA CIL.	NITRILO

00127 P - Juego completo
00586 P - Cabeza de Cilindro

9-614 - Kit O'ring Completo
8-614 - Kit O'ring Cabeza Cil.

20411 P - HONDA CB 190

EQUIVALENTES

CODIGO	UNIDAD	MATERIAL
20411 P	JUEGO COMPLETO	PREMIUM C/T. VALV.
21411 P	CABEZA DE CILINDRO	PREMIUM C/T. VALV.
25340 A/M	BASE DE CILINDRO	ALMA METAL
25341 M	TAPA DE CILINDRO	METAL
25342	ESCAPE	CHAPA
25343 P	EMBRAGUE	PREMIUM
25344 P	ALTERNADOR	PREMIUM
12-7758	TAPA DE VÁLVULAS	NITRILO

Bases de Cil. ALMA METAL
incluidas en las líneas
PREMIUM y PREMIUM C/O`RING



20411 P - Juego Completo

21411 P - Cabeza de Cilindro

25341 M 25340 A/M 25342

12-7758

25344 P 25343 P

00136 P - HONDA XR 200 (JAPÓN)

Bases de Cil. ALMA METAL
incluidas en las líneas
PREMIUM y PREMIUM C/O'RING



EQUIVALENTES

HONDA: NX 200 (JAPÓN) - STRADA CBX 200 (JAPÓN)

CODIGO	UNIDAD	MATERIAL
00136 P	JUEGO COMPLETO	PREMIUM
00136 P/O	JUEGO COMPLETO	PREMIUM C/O'RING
00594 P	CABEZA DE CILINDRO	PREMIUM
00594 P/O	CABEZA DE CILINDRO	PREMIUM C/O'RING
01781 A/M	BASE DE CILINDRO	ALMA METAL
01782 A	TAPA DE CILINDRO	MFT
01785	ESCAPE	CHAPA
02025 P	TENSOR CADENA	PREMIUM
01783 P	EMBRAGUE	PREMIUM
01784 P	CARTER	PREMIUM
01787 P	ENCENDIDO CHICO	PREMIUM
01798 P	ENCENDIDO IZQ.	PREMIUM
01786 P	ARBOL DE LEVAS	PREMIUM
01779 P	T/CENT. ACEITE	PREMIUM
23307	BOMBA ACEITE	ADAMITE
9-614	KIT O'RING COMPLETO	NITRILO
8-614	KIT O'RING CABEZA CIL.	NITRILO

00136 P - Juego completo

00594 P - Cabeza de Cilindro

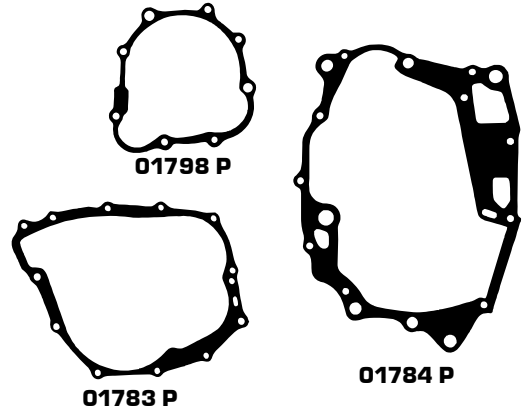
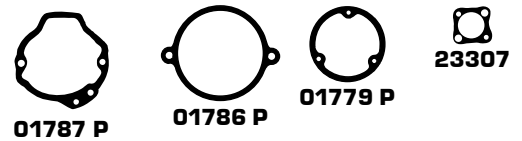
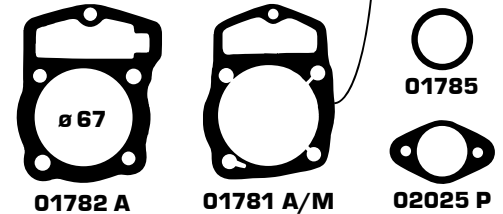

9-614 - Kit O'ring Completo

8-614 - Kit O'ring Cabeza Cil.

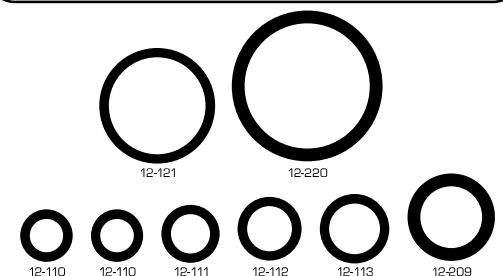
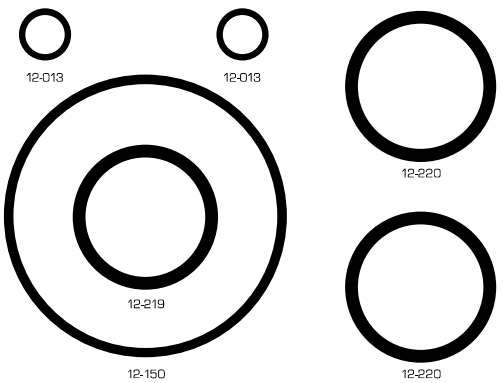

06143 P - HONDA XR 200 (BRASIL)

Bases de Cil. ALMA METAL
incluidas en las líneas
PREMIUM y PREMIUM C/O RING



EQUIVALENTES	
HONDA: NX 200 (BRASIL) - STRADA CBX 200 (BRASIL)	

CODIGO	UNIDAD	MATERIAL
06143 P	JUEGO COMPLETO	PREMIUM
06143 P/O	JUEGO COMPLETO	PREMIUM C/O RING
21066 P	CABEZA DE CILINDRO	PREMIUM
21066 P/O	CABEZA DE CILINDRO	PREMIUM C/O RING
23412 A/M	BASE DE CILINDRO	ALMA METAL
23413 M	TAPA DE CILINDRO	METAL
23414	ESCAPE	CHAPA
02025 P	TENSOR CADENA	PREMIUM
08163 P	EMBRAGUE	PREMIUM
23415 P	CARTER	PREMIUM
23416 P	ENCENDIDO CHICO	PREMIUM
23417 P	ENCENDIDO IZQ.	PREMIUM
23418 P	ARBOL DE LEVAS	PREMIUM
23419 P	T/CENT. ACEITE	PREMIUM
23307	BOMBA ACEITE	ADAMITE
9-614	KIT O RING COMPLETO	NITRILO
8-614	KIT O RING CABEZA CIL.	NITRILO

06143 P - Juego completo

21066 P - Cabeza de Cilindro

23413 M 23412 A/M 23414
 02025 P
 23416 P 23418 P 23419 P 23307
 23417 P
 08163 P 23415 P

9-614 - Kit O ring Completo

8-614 - Kit O ring Cabeza Cil.

12-013 12-013 12-220
 12-219
 12-150 12-220
 12-121 12-220
 12-110 12-110 12-111 12-112 12-113 12-209

06227 P - HONDA TORNADO 250

Bases de Cil. ALMA METAL
incluidas en las líneas
PREMIUM y PREMIUM C/O'RING



EQUIVALENTES

HONDA: CBX 250 TWISTER

CODIGO	UNIDAD	MATERIAL
06227 P	JUEGO COMPLETO	PREMIUM C/T. VALV.
06227 P/O	JUEGO COMPLETO	PREM. C/O'RING Y T/V
06236 P	CABEZA DE CILINDRO	PREMIUM C/T. VALV.
06236 P/O	CABEZA DE CILINDRO	PREM. C/O'RING Y T/V
23476 A/M	BASE DE CILINDRO	ALMA METAL
23477 A	TAPA DE CILINDRO	MFT
23477 M	TAPA DE CILINDRO	METAL
23478	ESCAPE	CHAPA
23479 P	EMBRAGUE	PREMIUM
23480 P	CARTER	PREMIUM
23481 P	ALTERNADOR	PREMIUM
23482 M	TENSOR CADENA	METAL
12-7753	TAPA DE VÁLVULAS	NITRILO
9-617	KIT O'RING COMPLETO	NITRILO
8-617	KIT O'RING CABEZA CIL.	NITRILO

06143 P - Juego completo

21066 P - Cabeza de Cilindro

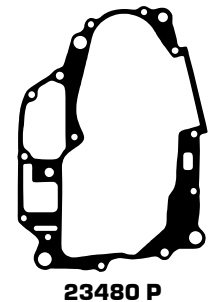
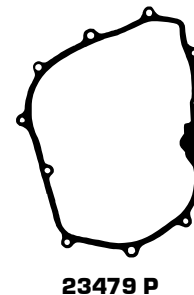
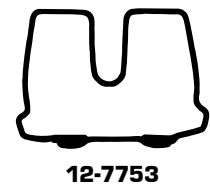
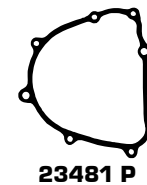
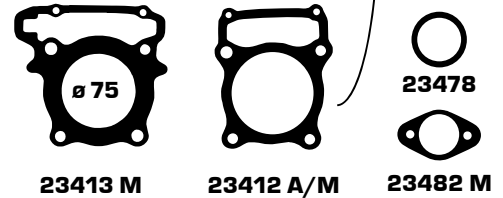

9-617 - Kit O'ring Completo

8-617 - Kit O'ring Cabeza Cil.

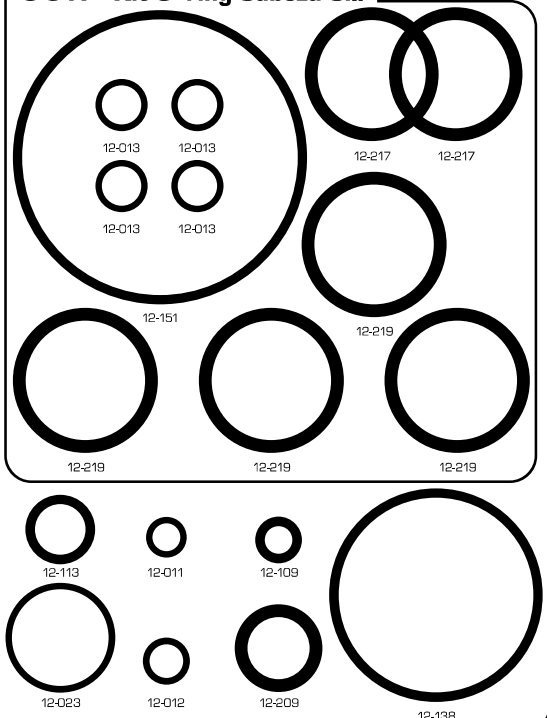

(Competición)

Tapa de Cilindro

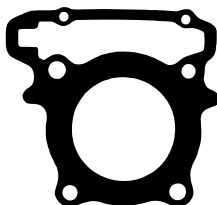

Código Diámetro

- 25220 - Ø 80
- 25366 - Ø 81
- 25367 - Ø 82
- 25221 - Ø 85
- 25222 - Ø 86
- 25223 - Ø 87
- 25224 - Ø 90
- 25225 - Ø 92
- 25226 - Ø 94
- 25227 - Ø 97

Material MFT

Código + A : Esp. 1,2
Código + B : Esp. 1,5
Código + C : Esp. 2,6
Ej: 25220 B
Tapa Cil. Tornado/Twister
Ø 80 MFT Esp. 1,5 mm
Ej: 25230 B
Base Cil. Tornado/Twister
Ø 88 MFT Esp. 1,5 mm

Base de Cilindro



Código Diámetro

- 25465 - Ø 83
- 25230 - Ø 88
- 25231 - Ø 99

20185 P - HONDA NX 400 FALCON M.'99

Bases de Cil. ALMA METAL
incluidas en las líneas
PREMIUM y PREMIUM C/O RING



EQUIVALENTES

HONDA: NX 400 FALCON

20185 P - Juego completo

21185 P - Cabeza de Cilindro



24476 M



02022 A/M



02024



02024

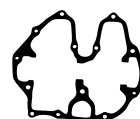

02027 M



02025 P



24503 P



24504 P

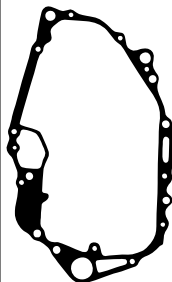

06754 M

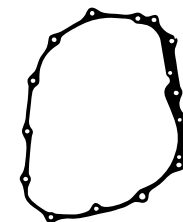

02026 P

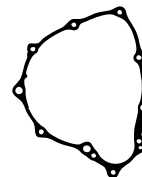

02028 P

9-618 - Kit O ring Completo

8-618 - Kit O ring Cabeza Cil.

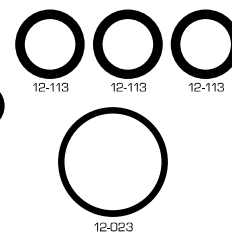
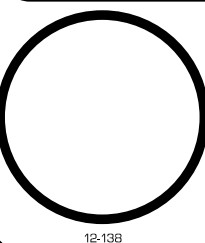
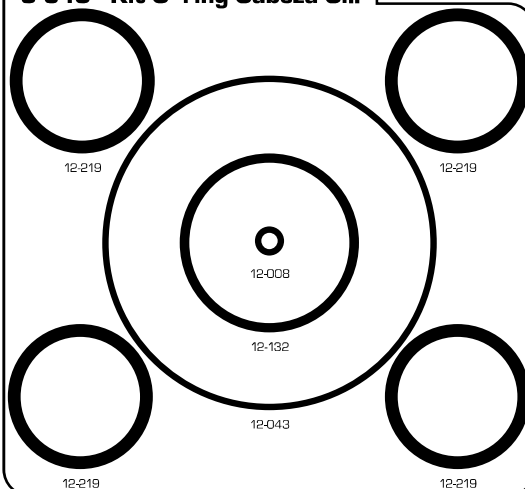

CODIGO	UNIDAD	MATERIAL
20185 P	JUEGO COMPLETO	PREMIUM
20185 P/O	JUEGO COMPLETO	PREMIUM C/O RING
21185 P	CABEZA DE CILINDRO	PREMIUM
21185 P/O	CABEZA DE CILINDRO	PREMIUM C/O RING
02022 A/M	BASE DE CILINDRO	ALMA METAL
24476 M	TAPA DE CILINDRO	METAL
02024	ESCAPE (2 X JGO)	CHAPA
02026 P	EMBRAGUE	PREMIUM
06754 P	CARTER	PREMIUM
24503 P	BOMBA AGUA	PREMIUM
02028 P	ALTERNADOR	PREMIUM
24504 P	JUNTA TRIANGULO	PREMIUM
02027 M	TAPA VALVULAS	METAL
02025 P	TENSOR CADENA	PREMIUM
9-618	KIT O RING COMPLETO	NITRILO
8-618	KIT O RING CABEZA CIL.	NITRILO

00161 P - HONDA XR 400

Bases de Cil. ALMA METAL
incluidas en las líneas
PREMIUM y PREMIUM C/O'RING



EQUIVALENTES

CODIGO	UNIDAD	MATERIAL
00161 P	JUEGO COMPLETO	PREMIUM
00161 P/O	JUEGO COMPLETO	PREMIUM C/O'RING
00612 P	CABEZA DE CILINDRO	PREMIUM
00612 P/O	CABEZA DE CILINDRO	PREMIUM C/O'RING
02022 A/M	BASE DE CILINDRO	ALMA METAL
02023 M	TAPA DE CILINDRO	METAL
02023 A	TAPA DE CILINDRO	MFT
02024	ESCAPE (2 X JGO)	CHAPA
02026 P	EMBRAGUE	PREMIUM
06754 P	CARTER	PREMIUM
02028 P	ALTERNADOR	PREMIUM
02027 M	TAPA VALVULAS	METAL
02025 P	TENSOR CADENA	PREMIUM
9-618	KIT O'RING COMPLETO	NITRILO
8-618	KIT O'RING CABEZA CIL.	NITRILO

00161 P - Juego completo

00612 P - Cabeza de Cilindro



02023 M



02022 A/M



02024



02024

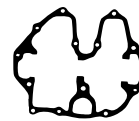

02027 M



02025 P

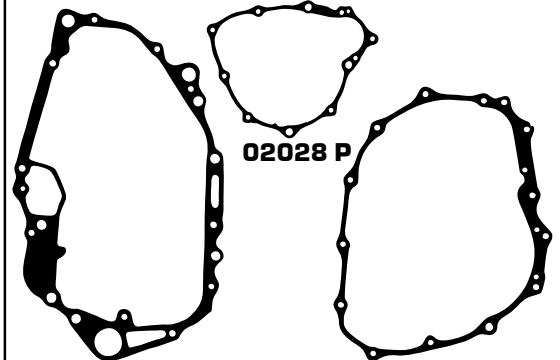

06754 M

02028 P

02026 P

9-618 - Kit O'ring Completo

8-618 - Kit O'ring Cabeza Cil.

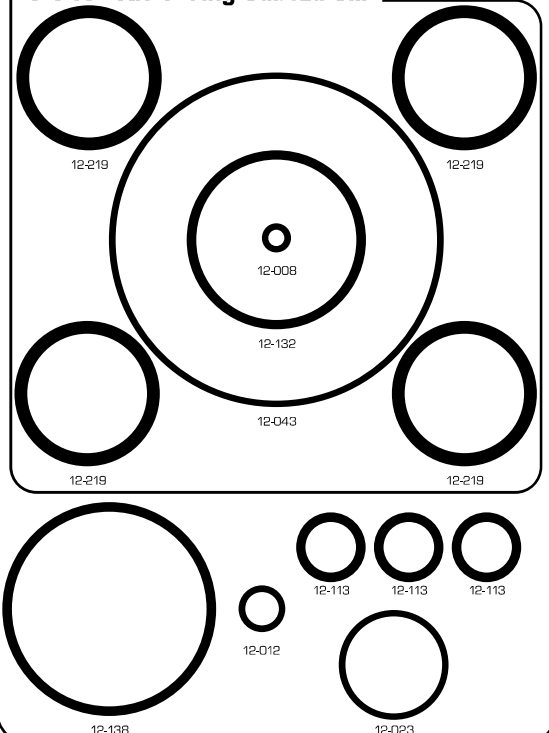

12-219

12-219

12-008

12-132

12-043

12-219

12-219

12-113

12-113

12-113

12-012

12-138

12-023



Motos y Cuatriciclos

20496 P - JAWA RVM TEKKEN 250

Bases de Cil. ALMA METAL
 incluidas en las líneas
PREMIUM y PREMIUM C/O RING



EQUIVALENTES		

CODIGO	UNIDAD	MATERIAL
20496 P	JUEGO COMPLETO	PREMIUM
21496 P	CABEZA DE CILINDRO	PREMIUM
25397 A/M	BASE DE CILINDRO	ALMA METAL
25398 M	TAPA DE CILINDRO	METAL
25399	ESCAPE	CHAPA
25400 P	ADMISION (2 X JGO.)	PREMIUM
25401 M	TENSOR CADENA	METAL
25402 P	T/CENT. ACEITE	PREMIUM
25403 P	T/ARBOL DE LEVAS	PREMIUM
25404 P	EMBRAGUE	PREMIUM
25405 P	ENCENDIDO	PREMIUM
25406 P	CARTER	PREMIUM
25407	BOMBA ACEITE	ADAMITE

20496 P - Juego Completo

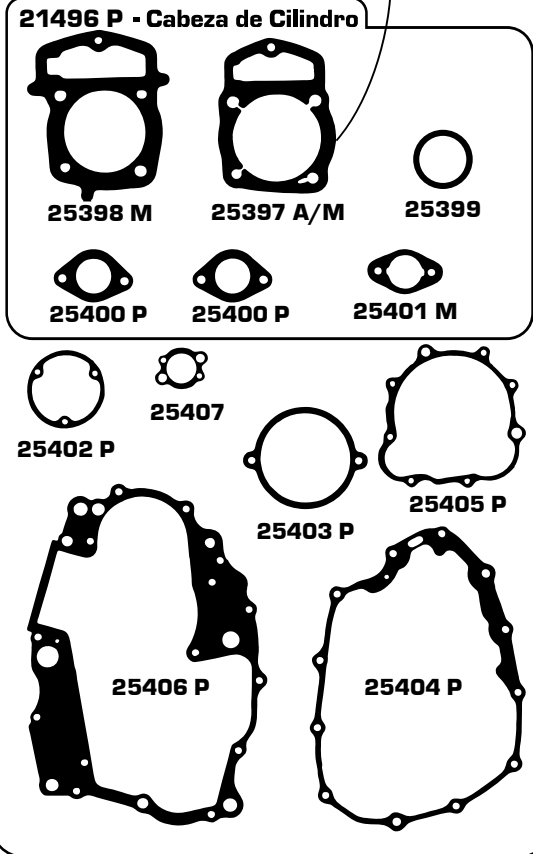

20377 P - JAWA 300 E (SIN BAL.)

Bases de Cil. ALMA METAL
incluidas en las líneas
PREMIUM y PREMIUM C/O'RING

Metal Material Premium

EQUIVALENTES	
JAWA: 300 - 6 / 300 - 9	

CODIGO	UNIDAD	MATERIAL
20377 P	JUEGO COMPLETO	PREMIUM
20377 P/O	JUEGO COMPLETO	PREMIUM C/O'RING
21377 P	CABEZA DE CILINDRO	PREMIUM
21377 P/O	CABEZA DE CILINDRO	PREMIUM C/O'RING
25291 A/M	BASE DE CILINDRO	ALMA METAL
25201 M	TAPA DE CILINDRO	METAL
25292	ESCAPE (2 X JGO.)	CHAPA
25296 P	CARTER	PREMIUM
25293 P	EMBRAGUE	PREMIUM
25294 P	ALTERNADOR	PREMIUM
25295 P	C/TAPA ALTERNADOR	PREMIUM
9-646	KIT O'RING COMPLETO	NITRILO
8-646	KIT O'RING CABEZA CIL.	NITRILO

20377 P - Juego Completo

21377 P - Cabeza de Cilindro

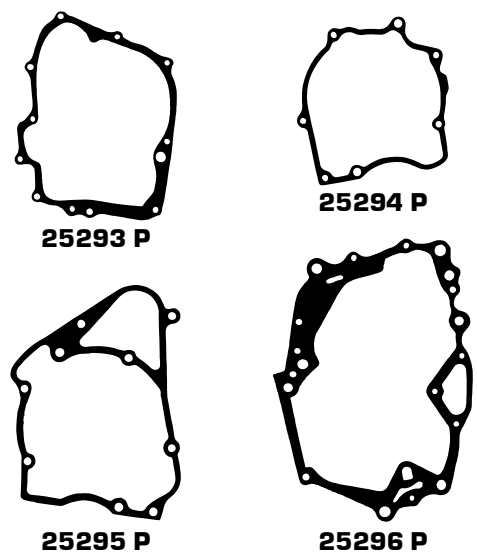
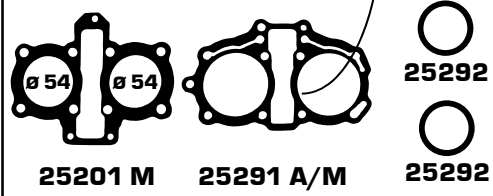

9-646 - Kit O'ring Completo

8-646 - Kit O'ring Cabeza Cil.

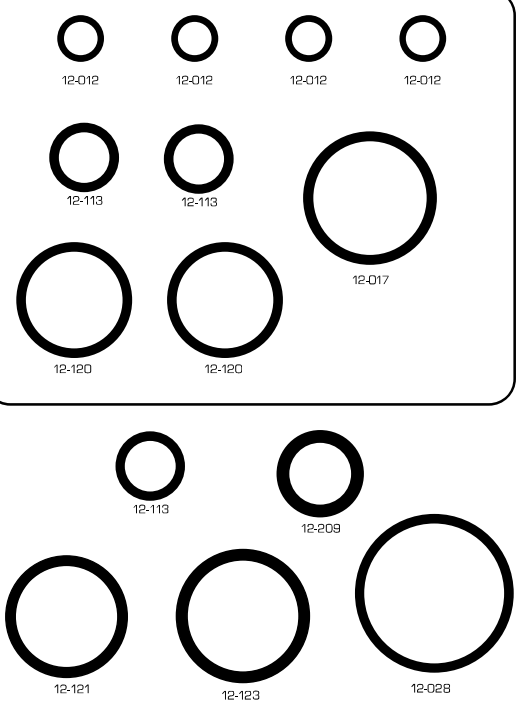



Motos y Cuatriciclos

20378 P - JAWA 350 9 (SIN BAL.)

Bases de Cil. ALMA METAL
incluidas en las líneas
PREMIUM y PREMIUM C/O'RING



EQUIVALENTES	
JAWA: SPYDER 350 / RUTA 40 350 / DAYTONA 350	
BOBBER 350	

CODIGO	UNIDAD	MATERIAL
20378 P	JUEGO COMPLETO	PREMIUM
20378 P/O	JUEGO COMPLETO	PREMIUM C/O'RING
21378 P	CABEZA DE CILINDRO	PREMIUM
21378 P/O	CABEZA DE CILINDRO	PREMIUM C/O'RING
25297 A/M	BASE DE CILINDRO	ALMA METAL
25201 M	TAPA DE CILINDRO	METAL
25298	ESCAPE (2 X JGO.)	CHAPA
25302 P	CARTER	PREMIUM
25299 P	EMBRAGUE	PREMIUM
25300 P	ALTERNADOR	PREMIUM
25301 P	C/TAPA ALTERNADOR	PREMIUM
9-646	KIT O'RING COMPLETO	NITRILO
8-646	KIT O'RING CABEZA CIL.	NITRILO

20378 P - Juego Completo

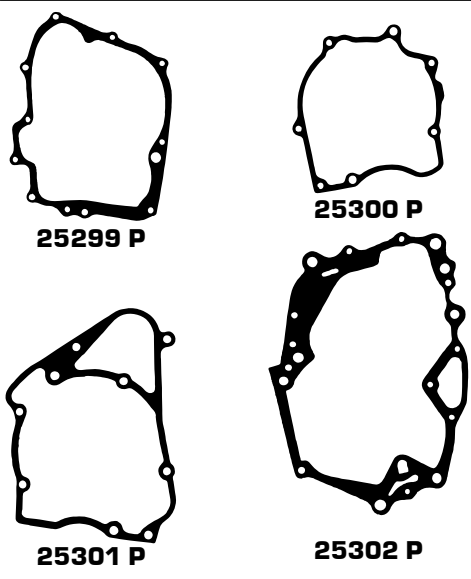
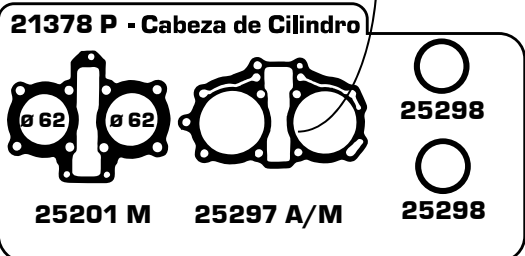

9-646 - Kit O'ring Completo

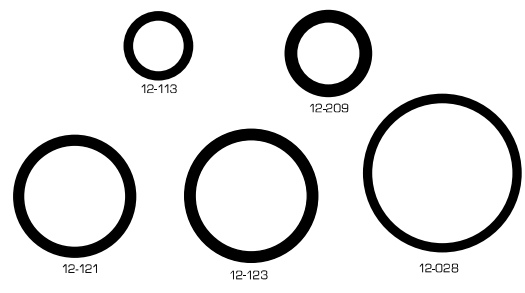
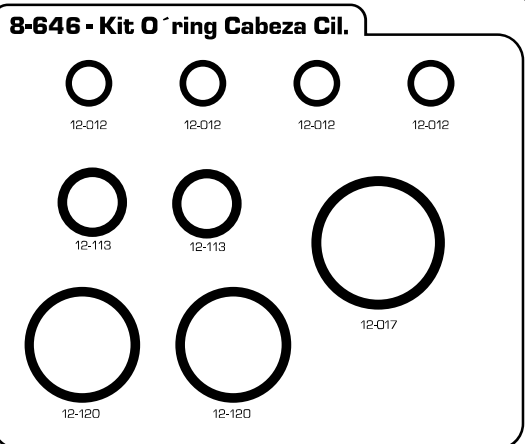



Motos y Cuatriciclos

20136 P - KELLER MX 260

EQUIVALENTES

BLACKSTONE: MX 300 (4 VALV.)

CORVEN: TRX 250

GILERA: 250 RR-15 - G1 300 RR

ZANELLA: FX 300 MAD MAX

CODIGO	UNIDAD	MATERIAL
20136 P	JUEGO COMPLETO	PREMIUM
21136 P	CABEZA DE CILINDRO	PREMIUM
24095 A/M	BASE DE CILINDRO	ALMA METAL
24096 M	TAPA DE CILINDRO	METAL
24097	ESCAPE	CHAPA
24098 P	EMBRAGUE	PREMIUM
24099 P	CARTER	PREMIUM
24100 P	ALTERNADOR	PREMIUM
24101 P	TENSOR CADENA	PREMIUM
25396 P	BOMBA AGUA	PREMIUM

Bases de Cil. ALMA METAL
incluidas en las líneas
PREMIUM y PREMIUM C/O RING



20136 P - Juego Completo

21136 P - Cabeza de Cilindro

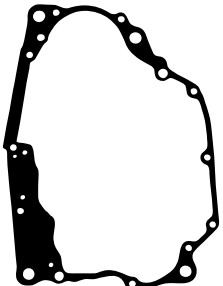
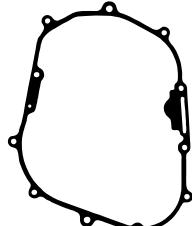
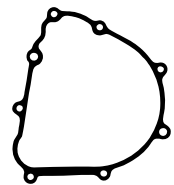
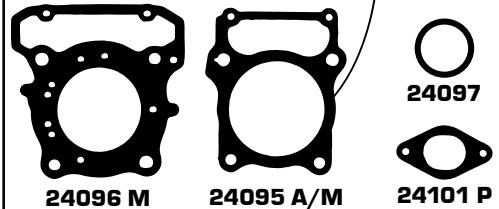

20290 P - KELLER 260 STRATUS

Bases de Cil. ALMA METAL
incluidas en las líneas
PREMIUM y PREMIUM C/O'RING



EQUIVALENTES

KELLER: QUASAR 260 - R 260 (HASTA M.2013)

CODIGO	UNIDAD	MATERIAL
20290 P	JUEGO COMPLETO	PREMIUM
20290 P/O	JUEGO COMPLETO	PREMIUM C/O'RING
21290 P	CABEZA DE CILINDRO	PREMIUM
21290 P/O	CABEZA DE CILINDRO	PREMIUM C/O'RING
23412 A/M	BASE DE CILINDRO	ALMA METAL
24477 M	TAPA DE CILINDRO	METAL
24477 A	TAPA DE CILINDRO	MFT
01782	ESCAPE	CHAPA
02025 P	TENSOR CADENA	PREMIUM
08867 P	EMBRAGUE	PREMIUM
25008 P	CARTER	PREMIUM
01332 P	ENCENDIDO IZQ.	PREMIUM
01786 P	ARBOL DE LEVAS	PREMIUM
06696 P	CENTRIFUGO ACEITE	PREMIUM
9-643	KIT O'RING COMPLETO	NITRILO
8-643	KIT O'RING CABEZA CIL.	NITRILO

20290 P - Juego completo

21290 P - Cabeza de Cilindro



24477 M



23412 A/M



01782



02025 P

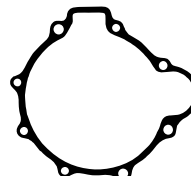

01332 P



01786 P



06696 P

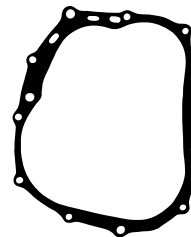

08867 P



25008 P

9-643 - Kit O'ring Completo

8-643 - Kit O'ring Cabeza Cil.

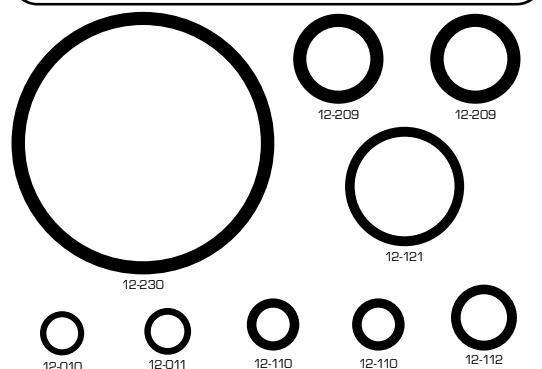
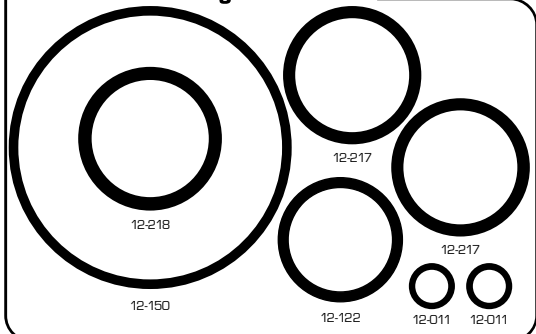

00227 P - MONDIAL MD/HD 125

Bases de Cil. ALMA METAL
incluidas en las líneas
PREMIUM y PREMIUM C/O'RING



EQUIVALENTES

MONDIAL: RD 125 (VAR.)
CERRO: STREET 125
KONISA: LF 125

CODIGO	UNIDAD	MATERIAL
00227 P	JUEGO COMPLETO	PREMIUM C/T. VALV.
00227 P/O	JUEGO COMPLETO	PREM. C/O'RING Y T/V
00588 P	CABEZA DE CILINDRO	PREMIUM
00588 P/O	CABEZA DE CILINDRO	PREM. C/O'RING Y T/V
02430 A/M	BASE DE CILINDRO	ALMA METAL
02431 A	TAPA DE CILINDRO	MFT
02432	ESCAPE	CHAPA
02433 P	ADMISION (2 X JGO)	PREMIUM
02434 P	EMBRAGUE	PREMIUM
03437 P	CARTER	PREMIUM
02435	BOMBA ACEITE	ADAMITE
02438 P	ENCENDIDO IZQ.	PREMIUM
02436 P	T/CENT. ACEITE	PREMIUM
12-7545	TAPA DE VÁLVULAS	NITRILO
9-641	KIT O'RING COMPLETO	NITRILO
8-641	KIT O'RING CABEZA CIL.	NITRILO

00227 P - Juego completo

00588 P - Cabeza de Cilindro



02431 A



02430 A/M



02433 P



02433 P



02432



12-7545



02436 P



02435



02438 P

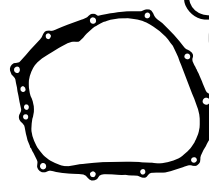

02434 P



02437 P

9-641 - Kit O'ring Completo

8-641 - Kit O'ring Cabeza Cil.



12-011



12-117

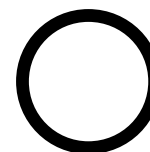

12-219



12-012



12-012



12-207



12-209



12-115

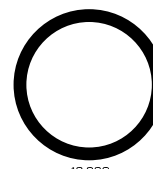

12-220

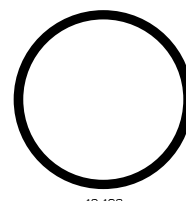

12-132

20122 P - MOTOMEL 125 X3M

Bases de Cil. ALMA METAL
incluidas en las líneas
PREMIUM y PREMIUM C/O'RING



EQUIVALENTES	
GILERA:	VC 125 F/D
MAVERICK:	CITY 125 (VAR.) / MOTOMEL: CG 125 - TOP 125 (VAR.)
SUMO:	CG 125 (VAR.)
ZANELLA:	SAPUCAI 125 4T. - RX 125 M.NVO.

CODIGO	UNIDAD	MATERIAL
20122 P	JUEGO COMPLETO	PREMIUM C/T. VALV.
20122 P/O	JUEGO COMPLETO	PREM. C/O'RING Y T/V
21122 P	CABEZA DE CILINDRO	PREMIUM
21122 P/O	CABEZA DE CILINDRO	PREM. C/O'RING Y T/V
24235 A/M	BASE DE CILINDRO	ALMA METAL
24236 A	TAPA DE CILINDRO	MFT
24237	ESCAPE	CHAPA
24238 P	ADMISION (2 X JGO)	PREMIUM
24239 P	EMBRAGUE	PREMIUM
24240 P	CARTER	PREMIUM
24241	BOMBA ACEITE	ADAMITE
24242 P	ENCENDIDO IZQ.	PREMIUM
24243 P	T/CENT. ACEITE	PREMIUM
12-7545	TAPA DE VÁLVULAS	NITRILO
9-642	KIT O'RING COMPLETO	NITRILO
8-642	KIT O'RING CABEZA CIL.	NITRILO

20122 P - Juego completo

21122 P - Cabeza de Cilindro



24236 A



24235 A/M



24238 P



24238 P



24237



12-7545



24243 P



24241

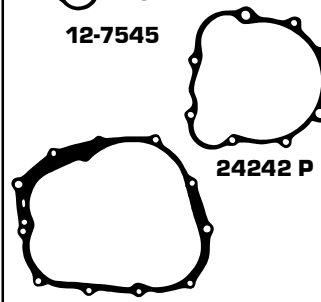

24242 P



24240 P

24239 P

9-642 - Kit O'ring Completo

8-642 - Kit O'ring Cabeza Cil.

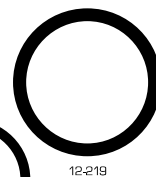
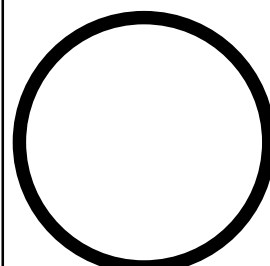
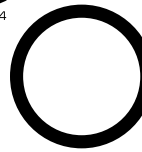
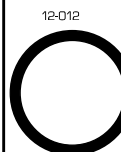

20104 P - MOTOMEL SKUA 150 (VAR.)

Bases de Cil. ALMA METAL
incluidas en las líneas
PREMIUM y PREMIUM C/O'RING



EQUIVALENTES
GILERA: GA 150 / CERRO: PRINCE 150 (VAR.) - CE 150 (VAR.)
IMSA: ROAD 150 / MONDIAL: RD 150 (VAR.) TD 150 - HD 150
MOTOMEL: HD 150 (VAR.)
ZANELLA: HJ 150

CODIGO	UNIDAD	MATERIAL
20104 P	JUEGO COMPLETO	PREMIUM C/T. VALV.
20104 P/O	JUEGO COMPLETO	PREM. C/O'RING Y T/V
21105 P	CABEZA DE CILINDRO	PREMIUM
21105 P/O	CABEZA DE CILINDRO	PREM. C/O'RING Y T/V
23822 A/M	BASE DE CILINDRO	ALMA METAL
23823 A	TAPA DE CILINDRO	MFT
23823 M	TAPA DE CILINDRO	METAL
23824	ESCAPE	CHAPA
23825 P	ADMISION (2 X JGO)	PREMIUM
23826 P	EMBRAGUE	PREMIUM
23827 P	CARTER	PREMIUM
23828	BOMBA ACEITE	ADAMITE
23830 P	ENCENDIDO IZQ.	PREMIUM
23832	T/CENT. ACEITE	PREMIUM
12-7545	TAPA DE VÁLVULAS	NITRILO
9-642	KIT O'RING COMPLETO	NITRILO
8-642	KIT O'RING CABEZA CIL.	NITRILO

20104 P - Juego Completo

21105 P - Cabeza de Cilindro

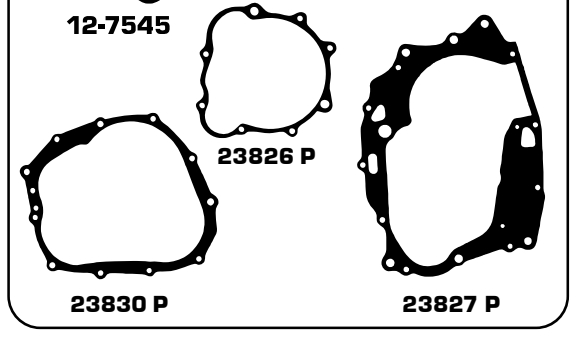
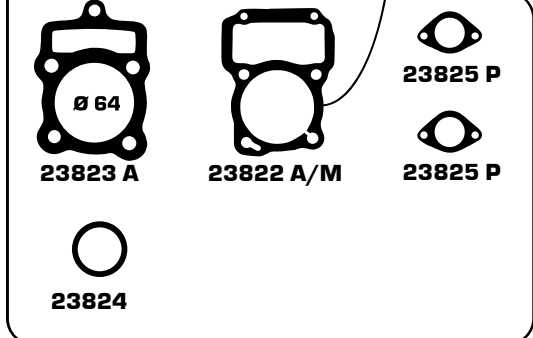

9-642 - Kit O'ring Completo

8-642 - Kit O'ring Cabeza Cil.

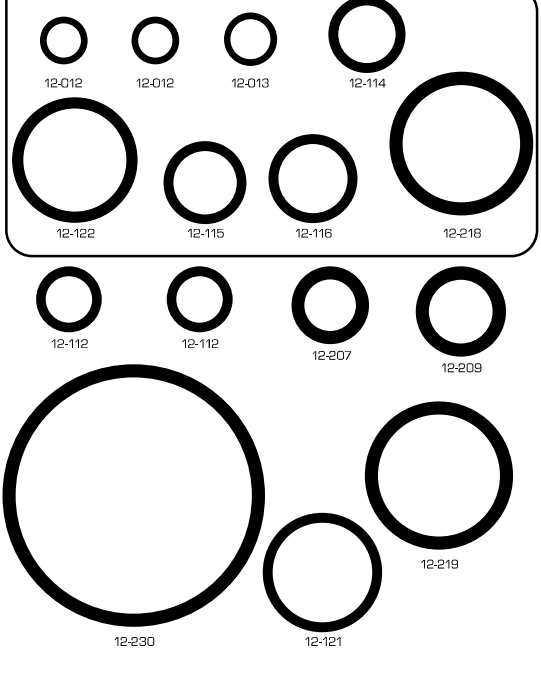

Bases de Cil. ALMA METAL
incluidas en las líneas PREMIUM



06193 P - MOTOMEL VX 150

EQUIVALENTES

BRAVA: WINSTAR 150 / GUERRERO: KRYON 150
CERRO: R9 125 / MONDIAL: HD 150 (SCOOTER)
MOTOMEL: SL 125 / KELLER: E-XTREME 150 - CONQUISTAR 150
VESPA: PHANTOM 150 (SCOOTER) / ZANELLA: ZSC 125

CODIGO	UNIDAD	MATERIAL
06193 P	JUEGO COMPLETO	PREMIUM C/T. VALV.
06470 P	CABEZA DE CILINDRO	PREMIUM C/T. VALV.
08884 A/M	BASE DE CILINDRO	ALMA METAL
08885 M	TAPA DE CILINDRO	METAL
08885 A	TAPA DE CILINDRO	MFT
08886	ESCAPE	CHAPA
08887 P	ADMISION	PREMIUM
08888 P	CARTER	PREMIUM
08915	TAPA DE VALVULAS	NITRILO
08889 P	CADENA	PREMIUM
08890 P	TENSOR CADENA	PREMIUM
23680 P	TRANSMISION	PREMIUM
08891 P	CARTER LATERAL	PREMIUM

06193 P - Juego Completo

06470 P - Cabeza de Cilindro

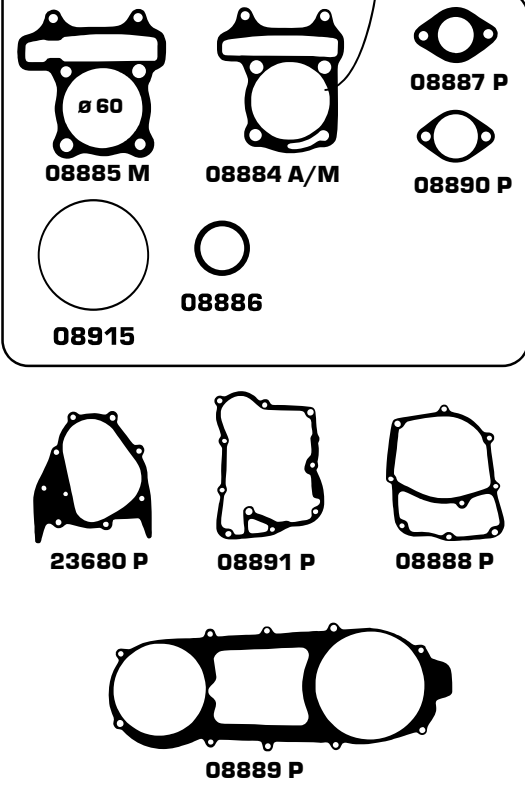



Motos y Cuatriciclos

06200 P - MOTOMEL 200 DAKAR (CADENERO)

Bases de Cil. ALMA METAL
incluidas en las líneas
PREMIUM y PREMIUM C/O RING

EQUIVALENTES	
GUERRERO:	TUNDRA 200 (CAD.)
CERRO:	COLT 200 - 250 (CUATRICICLO)
MOTOMEL:	SR 200

CODIGO	UNIDAD	MATERIAL
06200 P	JUEGO COMPLETO	PREMIUM
06200 P/O	JUEGO COMPLETO	PREMIUM C/O RING
06479 P	CABEZA DE CILINDRO	PREMIUM
06479 P/O	CABEZA DE CILINDRO	PREMIUM C/O RING
08929 A/M	BASE DE CILINDRO	ALMA METAL
08928 A	TAPA DE CILINDRO	MFT
23303	ESCAPE	CHAPA
23304 P	TENSOR CADENA	PREMIUM
23305 P	EMBRAGUE	PREMIUM
23306 P	CARTER	PREMIUM
23308 P	ENCENDIDO CHICO	PREMIUM
23309 P	ENCENDIDO IZQ.	PREMIUM
23310 P	ARBOL DE LEVAS	PREMIUM
23311 P	CENTRIFUGO ACEITE	PREMIUM
23307	BOMBA ACEITE	ADAMITE
9-643	KIT O RING COMPLETO	NITRILO
8-643	KIT O RING CABEZA CIL.	NITRILO

06200 P - Juego completo

06479 P - Cabeza de Cilindro

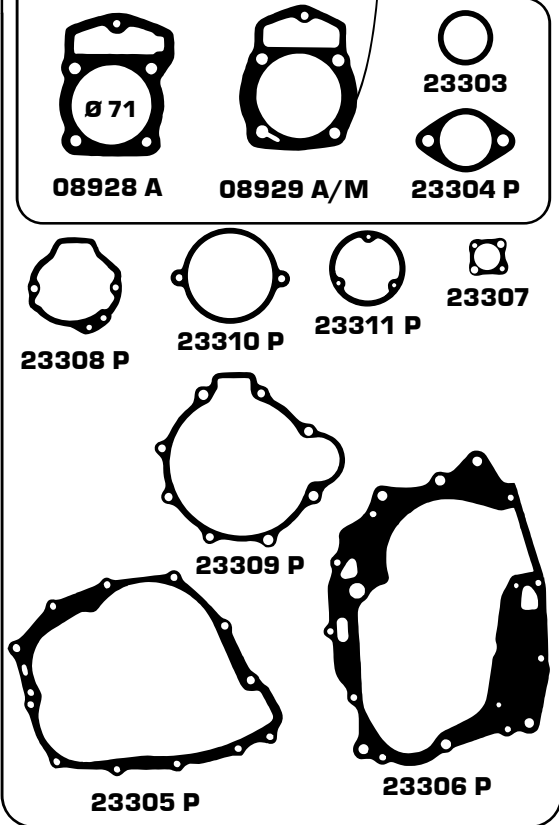

9-643 - Kit O ring Completo

8-643 - Kit O ring Cabeza Cil.

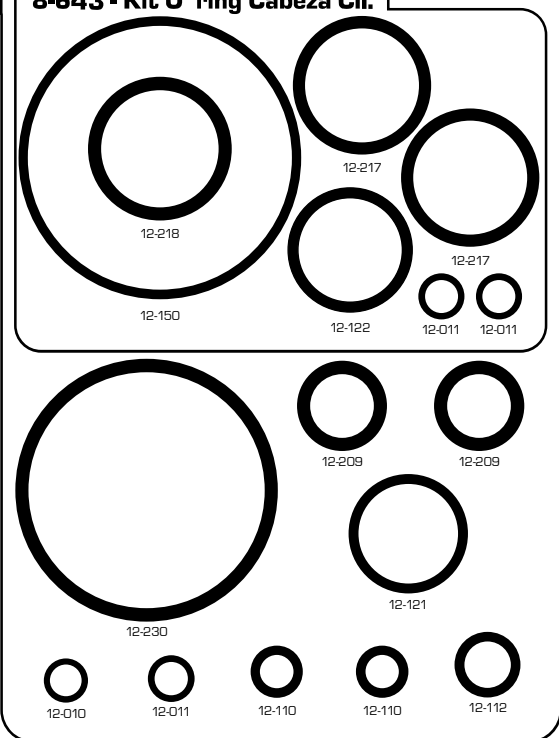

06177 P - MOTOMEL DAKAR 200 (VARILLERO)

Bases de Cil. ALMA METAL incluidas en las líneas PREMIUM y PREMIUM C/O'RING



EQUIVALENTES
APPIA: HARDWING 200 - SL 200
CERRO: SCRATCH 200 - COLT 200
GILERA: 200 (VAR.) / YL 200 (CROPERA)
GUERRERO: TUNDRA 200
HONDA: CG 200 / KELLER: MIRACLE 200
MONDIAL: TD 200 - RD 200
MOTOMEL: CUSTOM 200 (VAR.) - SR 200
SUMO: SL 200
ZANELLA: Z TT 200 - RX 200

CODIGO	UNIDAD	MATERIAL
06177 P	JUEGO COMPLETO	PREMIUM C/T. VALV.
06177 P/O	JUEGO COMPLETO	PREM. C/O'RING Y T/V
06453 P	CABEZA DE CILINDRO	PREMIUM
06453 P/O	CABEZA DE CILINDRO	PREM. C/O'RING Y T/V
08882 A/M	BASE DE CILINDRO	ALMA METAL
08883 A	TAPA DE CILINDRO	MFT
23015	ESCAPE	CHAPA
23016 P	TENSOR CADENA	PREMIUM
23017 P	EMBRAGUE	PREMIUM
23018 P	CARTER	PREMIUM
23019	BOMBA ACEITE	ADAMITE
23021 P	ENCENDIDO IZQ.	PREMIUM
23023 P	T/CENT. ACEITE	PREMIUM
12-7545	TAPA DE VÁLVULAS	NITRILLO
9-642	KIT O'RING COMPLETO	NITRILLO
8-642	KIT O'RING CABEZA CIL.	NITRILLO

06177 P - Juego Completo

06453 P - Cabeza de Cilindro



08883 A



08882 A/M



23015



23016 P

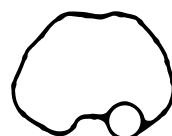

12-7545



23023 P



23019

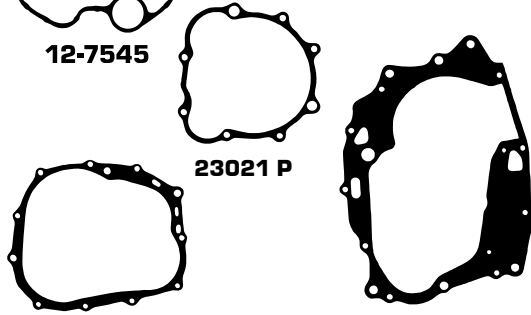

23021 P

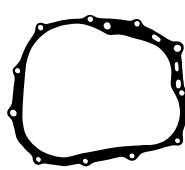

23017 P

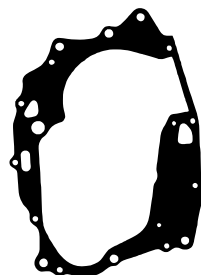

23018 P

9-642 - Kit O'ring Completo

8-642 - Kit O'ring Cabeza Cil.



12-012



12-012



12-013



12-114



12-122



12-115



12-116

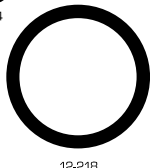

12-218



12-112



12-112



12-207



12-209

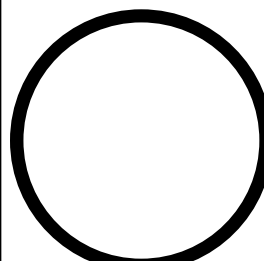

12-230



12-121



12-219



Motos y Cuatriciclos

20345 P - MOTOMEL 200 SIRIUS

Bases de Cil. ALMA METAL
incluidas en las líneas
PREMIUM y PREMIUM C/O RING

EQUIVALENTES	

CODIGO	UNIDAD	MATERIAL
20345 P	JUEGO COMPLETO	PREMIUM C/T. VALV.
20345 P/O	JUEGO COMPLETO	PREM. C/O RING Y T/V
21345 P	CABEZA DE CILINDRO	PREMIUM
21345 P/O	CABEZA DE CILINDRO	PREM. C/O RING Y T/V
08882 A/M	BASE DE CILINDRO	ALMA METAL
08883 A	TAPA DE CILINDRO	MFT
08883 M	TAPA DE CILINDRO	METAL
00692	ESCAPE	CHAPA
06693 P	ADMISION (2 X JGO)	PREMIUM
08867 P	EMBRAGUE	PREMIUM
25159 P	CARTER	PREMIUM
06697	BOMBA ACEITE	ADAMITE
08868 P	ENCENDIDO IZQ.	PREMIUM
06696 P	CENTRIFUGO ACEITE	PREMIUM
12-7545	TAPA VÁLVULAS	NITRILO
9-642	KIT O RING COMPLETO	NITRILO
8-642	KIT O RING CABEZA CIL.	NITRILO

20345 P - Juego completo

21345 P - Cabeza de Cilindro

08883 A 08882 A/M 06693 P
 06692
 12-7545 06696 P 06697
 08868 P 08867 P 25159 P

9-642 - Kit O ring Completo

8-642 - Kit O ring Cabeza Cil.

12-012 12-012 12-013 12-114
 12-122 12-115 12-116 12-218
 12-112 12-112 12-207 12-209
 12-230 12-121 12-219

20105 P - MOTOMEL SKUA 200 MOTARD (VAR. BAL. GDE.)

EQUIVALENTES

BRAVA: 200 (VAR.BAL.) / CORVEN: MOTARD 200 (VAR. BAL.)
GILERA: VCR 200 (VAR. BAL.)
MOTOMEL: KS 200 PISTERA (VAR.BAL.)-SKUA 200 MOTARD M. 2010 SKUA 250 (VAR. BAL.)-XMM 250 (VAR.BAL.)-XPLOTA 250 (VAR. BAL.)

CODIGO	UNIDAD	MATERIAL
20105 P	JUEGO COMPLETO	PREMIUM C/T. VALV.
20105 P/O	JUEGO COMPLETO	PREM. C/O'RING Y T/V
21106 P	CABEZA DE CILINDRO	PREMIUM
21106 P/O	CABEZA DE CILINDRO	PREM. C/O'RING Y T/V
23833 A/M	BASE DE CILINDRO	ALMA METAL
23434 A	TAPA DE CILINDRO	MFT
23835	ESCAPE	CHAPA
23836 P	ADMISION (2 X JGO)	PREMIUM
23837 P	EMBRAGUE	PREMIUM
23838 P	CARTER	PREMIUM
23839 P	BOMBA ACEITE	PREMIUM
23841 P	ENCENDIDO IZQ.	PREMIUM
23919 P	CENTRIFUGO ACEITE	PREMIUM
12-7545	TAPA VÁLVULAS	NITRILO
9-642	KIT O'RING COMPLETO	NITRILO
8-642	KIT O'RING CABEZA CIL.	NITRILO

20105 P - Juego completo

21106 P - Cabeza de Cilindro

Bases de Cil. ALMA METAL
incluidas en las líneas
PREMIUM y PREMIUM C/O' RING

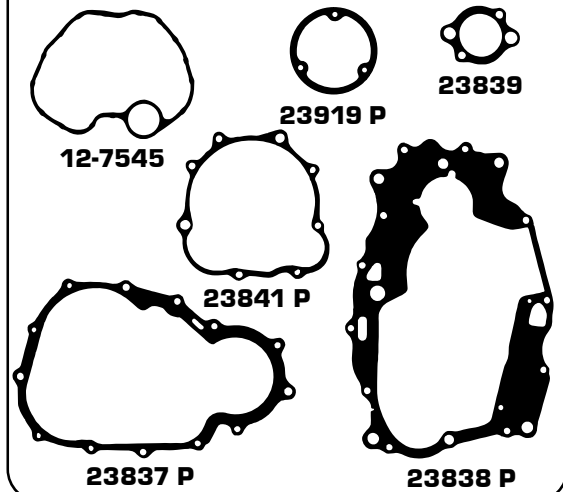
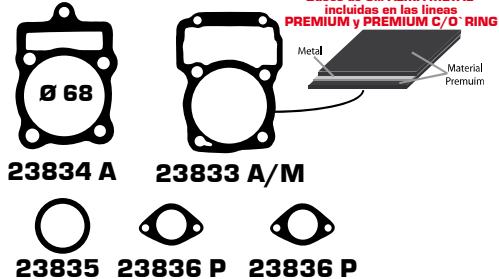

9-642 - Kit O'ring Completo

8-642 - Kit O'ring Cabeza Cil.

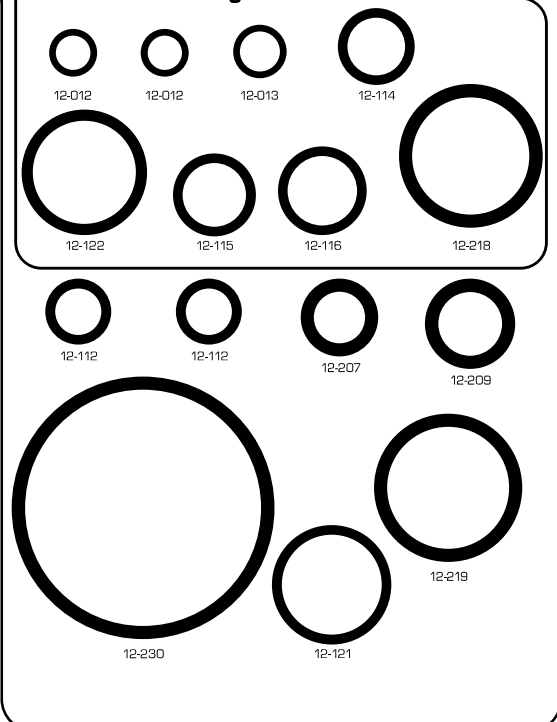



Motos y Cuatriciclos

20296 P - MOTOMEL XMM 250 (CAD. BAL.)

Bases de Cil. ALMA METAL
incluidas en las líneas
PREMIUM y PREMIUM C/O RING

EQUIVALENTES

CODIGO	UNIDAD	MATERIAL
20296 P	JUEGO COMPLETO	PREMIUM
20296 P/O	JUEGO COMPLETO	PREMIUM C/O RING
21296 P	CABEZA DE CILINDRO	PREMIUM
21296 P/O	CABEZA DE CILINDRO	PREMIUM C/O RING
24508 A/M	BASE DE CILINDRO	ALMA METAL
24509 M	TAPA DE CILINDRO	METAL
24509 A	TAPA DE CILINDRO	MFT
24510	ESCAPE	CHAPA
24511 P	ADMISION (2 X JGO)	PREMIUM
24512 P	EMBRAGUE	PREMIUM
24513 P	CARTER	PREMIUM
24514	BOMBA ACEITE	ADAMITE
24515 P	ENCENDIDO IZQ.	PREMIUM
24516 P	CENTRIFUGO ACEITE	PREMIUM
24517 P	ARBOL DE LEVAS	PREMIUM
02025 P	TENSOR CADENA	PREMIUM
9-643	KIT O RING COMPLETO	NITRILO
8-643	KIT O RING CABEZA CIL.	NITRILO

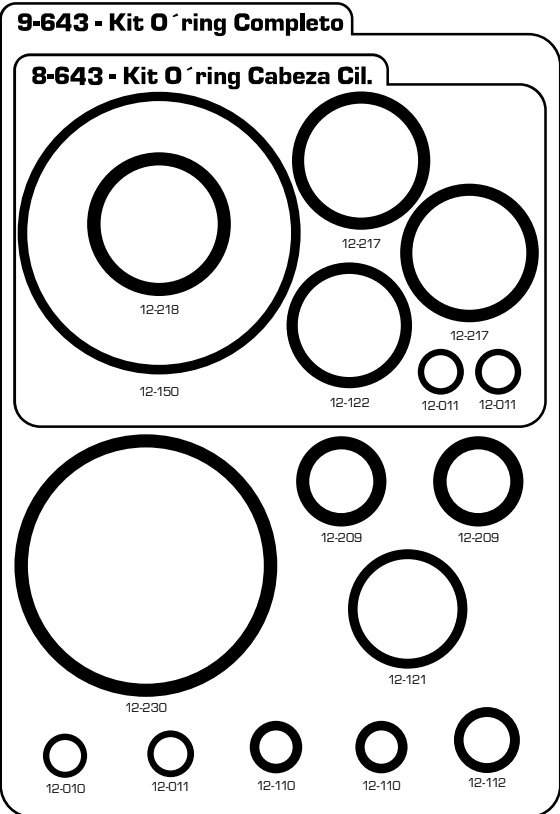
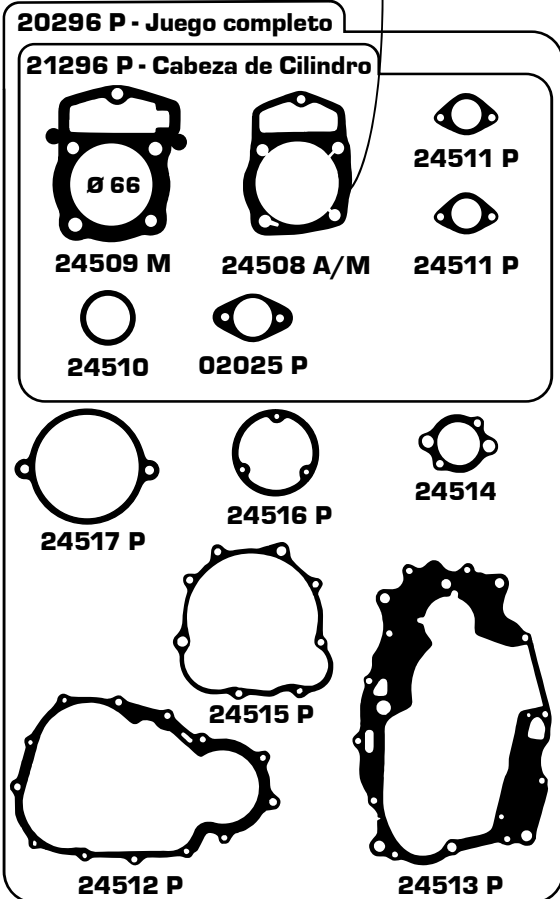



20119 P - MOTOMEL 250 XPLORA

Bases de Cil. ALMA METAL
incluidas en las líneas
PREMIUM y PREMIUM C/O'RING

EQUIVALENTES	
ATV:	WATER COOLER 200 / KELLER: QUAD RACE 250
OKINOI:	MOTARD 250 / MAVERICK: PANTHER 250 / MONDIAL: 256
MOTOMEL:	VOLKANO 250 / SCOUT: C MAX 250
SUMO:	RINO 250 / ZANELLA: FX SCORPION 250

CODIGO	UNIDAD	MATERIAL
20119 P	JUEGO COMPLETO	PREMIUM C/T. VALV.
20119 P/O	JUEGO COMPLETO	PREM. C/O'RING Y T/V
21120 P	CABEZA DE CILINDRO	PREMIUM
21120 P/O	CABEZA DE CILINDRO	PREM. C/O'RING Y T/V
24264 A/M	BASE DE CILINDRO	ALMA METAL
24265 A	TAPA DE CILINDRO	MFT
24266	ESCAPE	CHAPA
24267 P	ADMISION (2 X JGO)	PREMIUM
24268 P	EMBRAGUE	PREMIUM
24269 P	CARTER	PREMIUM
24270	BOMBA ACEITE	ADAMITE
24271 P	ENCENDIDO IZQ.	PREMIUM
24272 P	CENTRIFUGO ACEITE	PREMIUM
9-642	KIT O'RING COMPLETO	NITRILO
8-642	KIT O'RING CABEZA CIL.	NITRILO

20119 P - Juego completo

21120 P - Cabeza de Cilindro

12-7545

24272 P

24270

24271 P

24268 P

24269 P

9-642 - Kit O'ring Completo

8-642 - Kit O'ring Cabeza Cil.

12-012 **12-012** **12-013** **12-114**

12-122 **12-115** **12-116** **12-218**

12-112 **12-112** **12-207** **12-209**

12-230 **12-219** **12-121**



Motos y Cuatriciclos

20229 P - PANTHER 200 M.N.

Bases de Cil. ALMA METAL
incluidas en las líneas
PREMIUM y PREMIUM C/O RING



EQUIVALENTES

EQUIVALENTES

20229 P - Juego Completo

21229 P - Cabeza de Cilindro



23805 M

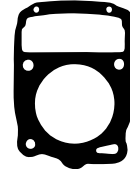

25418 A/M



25419

CODIGO	UNIDAD	MATERIAL
20229 P	JUEGO COMPLETO	PREMIUM C/T. VALV.
21229 P	CABEZA DE CILINDRO	PREMIUM C/T. VALV.
25418 A/M	BASE DE CILINDRO	ALMA METAL
23805 M	TAPA DE CILINDRO	METAL
25419	ESCAPE	CHAPA
25420 P	EMBRAGUE	PREMIUM
25422 P	CARTER	PREMIUM
12-7545	TAPA DE VÁLVULAS	NITRILO



12-7545

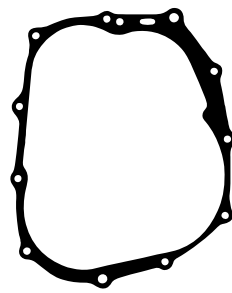

25420 P

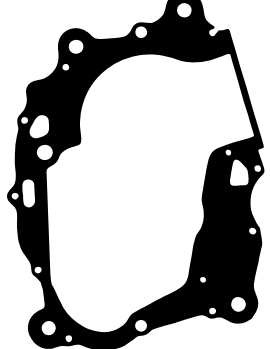

25422 P

20099 P - PANTHER 250

Bases de Cil. ALMA METAL
incluidas en las líneas
PREMIUM y PREMIUM C/O RING

EQUIVALENTES		

CODIGO	UNIDAD	MATERIAL
20099 P	JUEGO COMPLETO	PREMIUM
21101 P	CABEZA DE CILINDRO	PREMIUM
25432 A/M	BASE DE CILINDRO	ALMA METAL
25433 M	TAPA DE CILINDRO	METAL
25434	ESCAPE	CHAPA
25435 P	EMBRAGUE	PREMIUM
25436 P	CARTER	PREMIUM
25437 P	ENCENDIDO	PREMIUM
25438 P	CENTRIFUGO ACEITE	PREMIUM
25439 P	T/ARBOL DE LEVAS	PREMIUM

20099 P - Juego Completo

21101 P - Cabeza de Cilindro

Metal / Material Premium

00341 P - SUZUKI AX 100

Bases de Cil. ALMA METAL
incluidas en las líneas
PREMIUM y PREMIUM C/O RING



EQUIVALENTES
AX SAP: 100 / BAJAJ: 100 2T. / DA-DALT: 100 2T. / GILERA: AX 100
GUERRERO: MB 100 / MONDIAL: 100 2T. - AX 115
MOTOMEL: AX 100 / Q. AX: 100 CHINA / Q. JIAM: 100
SUZUKI: AX 115

CODIGO	UNIDAD	MATERIAL
00341 P	JUEGO COMPLETO	PREMIUM
00341 P/O	JUEGO COMPLETO	PREMIUM C/O RING
00769 P	CABEZA DE CILINDRO	PREMIUM
03082 A/M	BASE DE CILINDRO	ALMA METAL
03083 M	TAPA DE CILINDRO	METAL
03084	ESCAPE	CHAPA
03085 P	EMBRAGUE	PREMIUM
03086 P	CARTER	PREMIUM
03098	CUBA CARBURADOR	ADAMITE
03087 P	BOMBA ACEITE	PREMIUM
9-628	KIT O RING COMPLETO	NITRILO

00341 P - Juego completo

00769 P - Cabeza de Cilindro

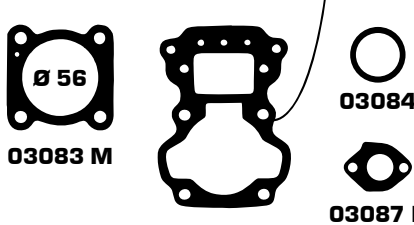
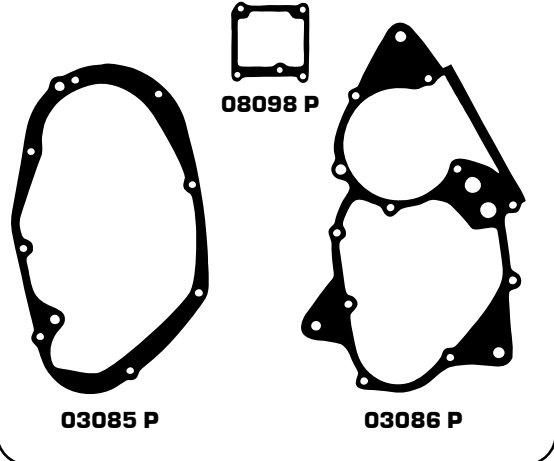
9-628 - Kit O ring Completo



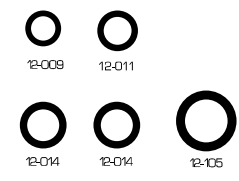

Motos y Cuatriciclos

20455 P - SUZUKI AN 125

Bases de Cil. ALMA METAL
incluidas en las líneas
PREMIUM y PREMIUM C/O RING



EQUIVALENTES

CODIGO	UNIDAD	MATERIAL
20455 P	JUEGO COMPLETO	PREMIUM
20455 P/O	JUEGO COMPLETO	PREMIUM C/O RING
21455 P	CABEZA DE CILINDRO	PREMIUM
25423 A/M	BASE DE CILINDRO	ALMA METAL
25424 M	TAPA DE CILINDRO	METAL
25425	ESCAPE	CHAPA
25426 P	TENSOR CADENA	PREMIUM
25427 P	RESPIRADERO	PREMIUM
25428 P	BOMBA ACEITE	PREMIUM
25429	EMBRAGUE	PREMIUM
25430 P	TRANSMISION	PREMIUM
9-649	KIT O RING COMPLETO	NITRILO

20455 P - Juego Completo

21455 P - Cabeza de Cilindro

25424 M 25423 A/M 25425

25427 P 25426 P

25428 P

25429 P 25430 P

9-649 - Kit O ring Completo

12-014 12-115

12-125 12-138

20097 P - SUZUKI EN 125

Bases de Cil. ALMA METAL
incluidas en las líneas
PREMIUM y PREMIUM C/O'RING

Metal
Material Premium

EQUIVALENTES

KEEWAY: RKS 150

CODIGO	UNIDAD	MATERIAL
20097 P	JUEGO COMPLETO	PREMIUM
20097 P/O	JUEGO COMPLETO	PREMIUM C/O'RING
21099 P	CABEZA DE CILINDRO	PREMIUM
23770 A/	BASE DE CILINDRO	ALMA METAL
23771 M	TAPA DE CILINDRO	METAL
23772	ESCAPE	CHAPA
23773 P	EMBRAGUE	PREMIUM
23774 P	ALTERNADOR	PREMIUM
24245 P	TENSOR DIST.	PREMIUM
9-633	KIT O'RING JUEGO COMP.	NITRILO

20097 P - Juego completo

21099 P - Cabeza de Cilindro

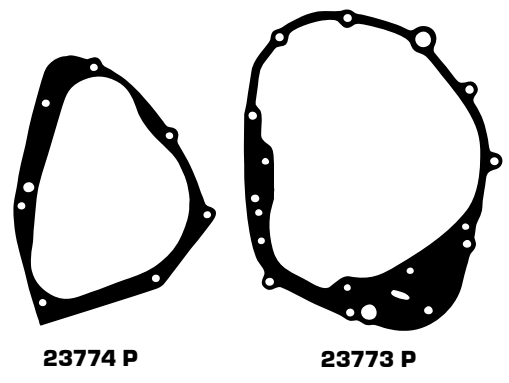
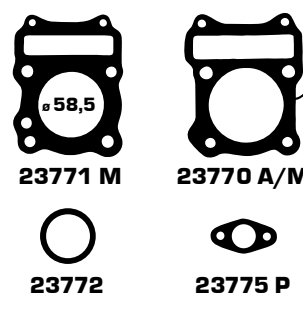

9-633 - Kit O`ring Completo

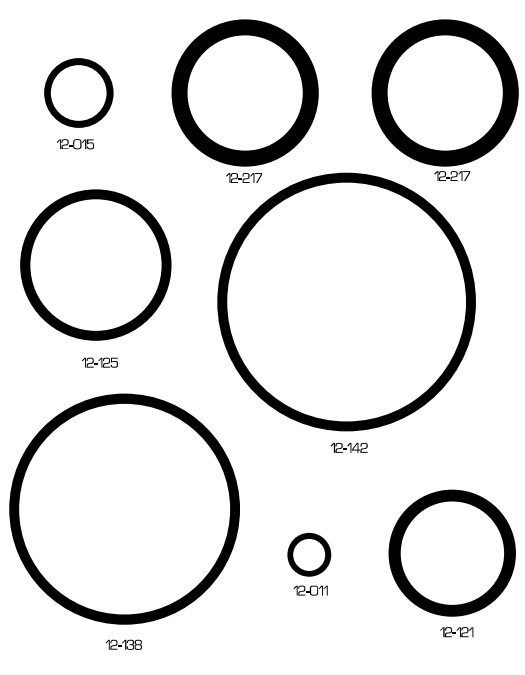

20456 P - SUZUKI GIXXER 160

Bases de Cil. ALMA METAL
incluidas en las líneas
PREMIUM y PREMIUM C/O RING

EQUIVALENTES

CODIGO	UNIDAD	MATERIAL
20456 P	JUEGO COMPLETO	PREMIUM
21456 P	CABEZA DE CILINDRO	PREMIUM
25380 A/M	BASE DE CILINDRO	ALMA METAL
25381 M	TAPA DE CILINDRO	METAL
25382	ESCAPE	CHAPA
25383 P	EMBRAGUE	PREMIUM
25384 P	ENCENDIDO	PREMIUM
25385 P	TENSOR CADENA	PREMIUM

20456 P - Juego Completo

21456 P - Cabeza de Cilindro

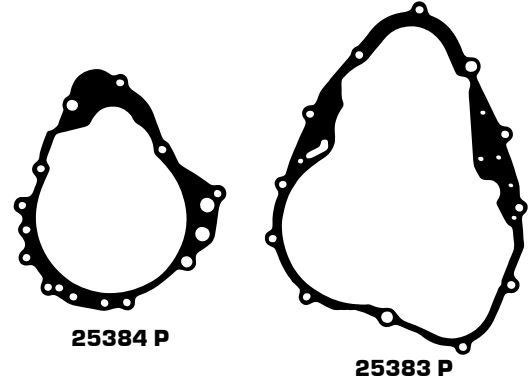
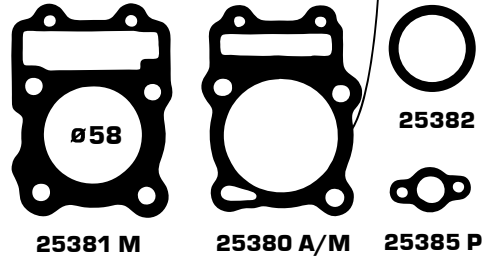

00421 P - YAMAHA CRYPTON 100

Bases de Cil. ALMA METAL
incluidas en las líneas
PREMIUM y PREMIUM C/O'RING

EQUIVALENTES	
YAMAHA: CRYPTON 105	

CODIGO	UNIDAD	MATERIAL
00421 P	JUEGO COMPLETO	PREMIUM
00421 P/O	JUEGO COMPLETO	PREMIUM C/O'RING
00845 P	CABEZA DE CILINDRO	PREMIUM
00845 P/O	CABEZA DE CILINDRO	PREMIUM C/O'RING
03850 A/M	BASE DE CILINDRO	ALMA METAL
03851 M	TAPA DE CILINDRO	METAL
03852	ESCAPE	CHAPA
03853 P	EMBRAGUE	PREMIUM
03854 P	ALTERNADOR	PREMIUM
03855 P	TENSOR CADENA	PREMIUM
03856	FILTRO ACEITE	ADAMITE
03857 P	ARANDELA	PREMIUM
24507 P	CARTER	PREMIUM
9-639	KIT O'RING COMPLETO	NITRILO
8-639	KIT O'RING CABEZA CIL.	NITRILO

00421 P - Juego completo

00845 P - Cabeza de Cilindro

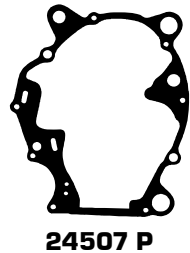
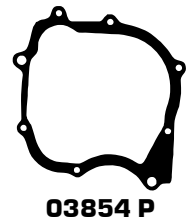
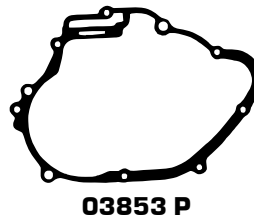
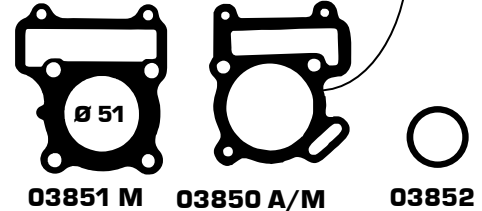

9-639 - Kit O'ring Completo

8-639 - Kit O'ring Cabeza Cil.

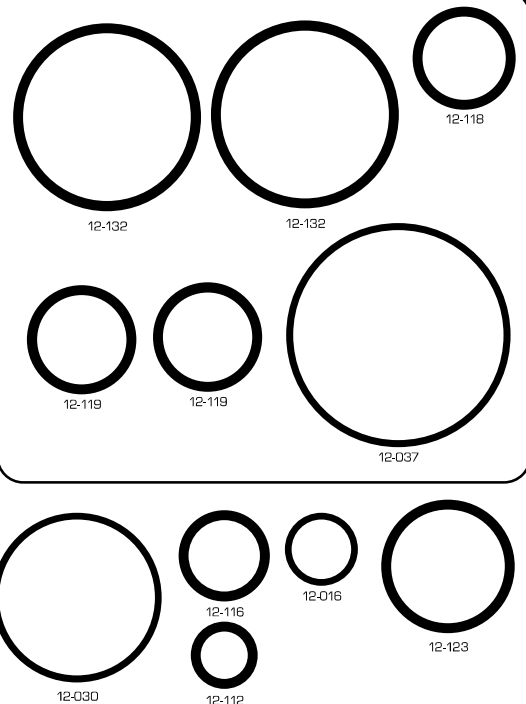



Motos y Cuatriciclos

20240 P - YAMAHA NEW CRYPTON 110

Bases de Cil. ALMA METAL
incluidas en las líneas
PREMIUM y PREMIUM C/O RING

EQUIVALENTES
JIANISHE: JS 125 F (CUB)

CODIGO	UNIDAD	MATERIAL
20240 P	JUEGO COMPLETO	PREMIUM
20240 P/O	JUEGO COMPLETO	PREMIUM C/O RING
21240 P	CABEZA DE CILINDRO	PREMIUM
21240 P/O	CABEZA DE CILINDRO	PREMIUM C/O RING
03850 A/M	BASE DE CILINDRO	ALMA METAL
24449 M	TAPA DE CILINDRO	METAL
24449 A	TAPA DE CILINDRO	MFT
03852	ESCAPE	CHAPA
03853 P	EMBRAGUE	PREMIUM
03854 P	ALTERNADOR	PREMIUM
03855 P	TENSOR CADENA	PREMIUM
03856	FILTRO ACEITE	ADAMITE
03857 P	ARANDELA	PREMIUM
24507 P	CARTER	PREMIUM
9-639	KIT O RING COMPLETO	NITRILO
8-639	KIT O RING CABEZA CIL.	NITRILO

20240 P - Juego completo



21240 P - Cabeza de Cilindro

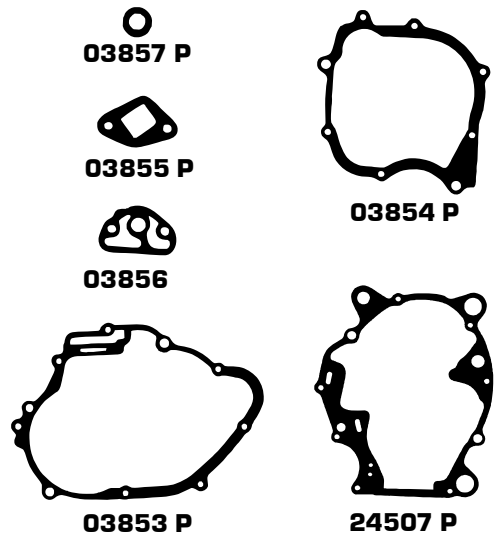
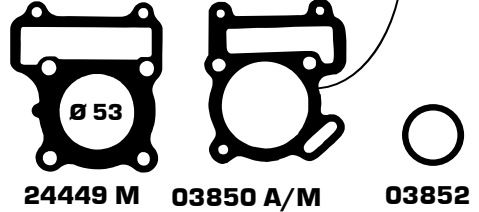

9-639 - Kit O ring Completo

8-639 - Kit O ring Cabeza Cil.

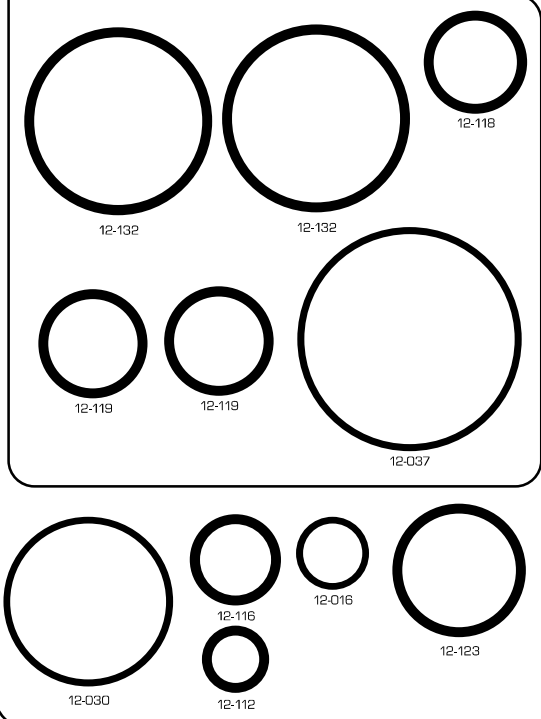

06078 P - YAMAHA YBR 125

Bases de Cil. ALMA METAL
incluidas en las líneas
PREMIUM y PREMIUM C/O RING

EQUIVALENTES

JIANSHE: JS 125 6B STREET M. 2011/13

JINCHENG: 125 M.N.

YAMAHA: XTZ 125

CODIGO	UNIDAD	MATERIAL
06078 P	JUEGO COMPLETO	PREMIUM
06078 P/O	JUEGO COMPLETO	PREMIUM C/O RING
06341 P	CABEZA DE CILINDRO	PREMIUM
06341 P/O	CABEZA DE CILINDRO	PREMIUM C/O RING
07117 A/M	BASE DE CILINDRO	ALMA METAL
07118 M	TAPA DE CILINDRO	METAL
07118 A	TAPA DE CILINDRO	MFT
07119	ESCAPE	CHAPA
07120 P	EMBRAGUE	PREMIUM
07122 P	ALTERNADOR	PREMIUM
07123 P	TENSOR CADENA	PREMIUM
07124 P	ARANDELA	PREMIUM
07121	FILTRO ACEITE	ADAMITE
24506 P	CARTER	PREMIUM
9-634	KIT O RING COMPLETO	NITRILO
8-634	KIT O RING CABEZA CIL.	NITRILO

06078 P - Juego completo

06341 P - Cabeza de Cilindro

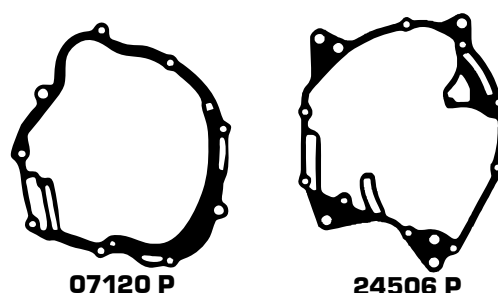
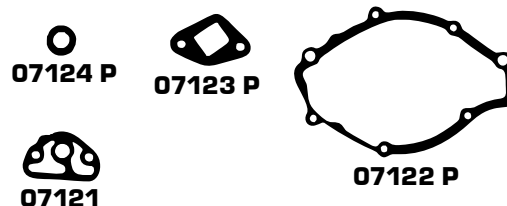
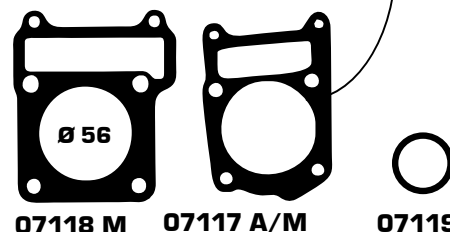

9-634 - Kit O ring Completo

8-634 - Kit O ring Cabeza Cil.

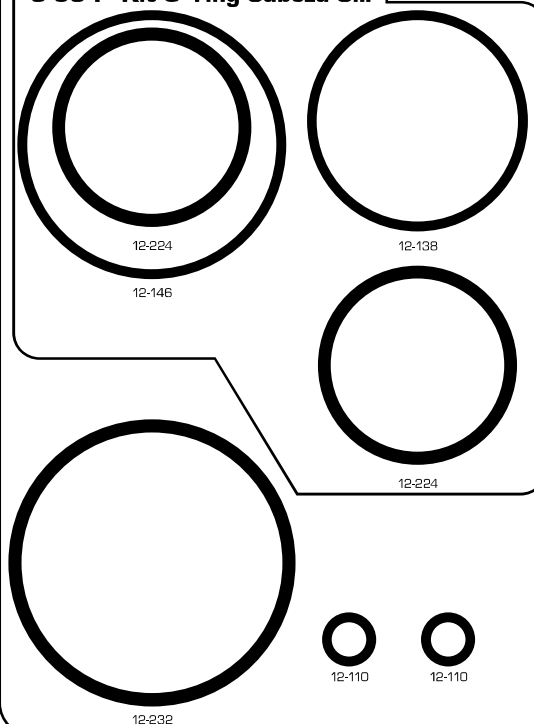



Motos y Cuatriciclos

20467 P - ZANELLA Z MAX TRUCK 200

Bases de Cil. ALMA METAL
incluidas en las líneas
PREMIUM y PREMIUM C/O RING



EQUIVALENTES	

CODIGO	UNIDAD	MATERIAL
20467 P	JUEGO COMPLETO	PREMIUM
21467 P	CABEZA DE CILINDRO	PREMIUM
25345 A/M	BASE DE CILINDRO	ALMA METAL
25346 M	TAPA DE CILINDRO	METAL
25347	ESCAPE	CHAPA
25348 P	EMBRAGUE	PREMIUM
25349 P	CARTER	PREMIUM
25350 P	T/ENC. IZQ.	PREMIUM

20467 P - Juego Completo

21467 P - Cabeza de Cilindro

25346 M 25345 A/M 25347

25350 P 25348 P 25349 P



Motos y Cuatriciclos

20092 P - ZANELLA PATAGONIA EAGLE 250 (CUSTOM)

EQUIVALENTES	
CORVEN:	INDIANA 256 / GILERA: VCR 250 - YL 275 - CUSTOM 250
CERRO:	PRINCE 250 / GUERRERO: GMX 250 (CUSTOM)
MONDIAL:	HD 250 CUSTOM - HD 254 / MOTOMEL: TRACKER 250
HAWKER 250 - RIDER 250 / KELLER:	EXCELENCE 250 (CUSTOM)

CODIGO	UNIDAD	MATERIAL
20092 P	JUEGO COMPLETO	PREMIUM C/T. VALV.
20092 P/O	JUEGO COMPLETO	PREM. C/O´RING Y T/V
21092 P	CABEZA DE CILINDRO	PREMIUM C/T. VALV.
21092 P/O	CABEZA DE CILINDRO	PREM. C/O´RING Y T/V
23721 A/M	BASE DE CILINDRO	ALMA METAL
23722 M	TAPA DE CILINDRO	METAL
23722 A	TAPA DE CILINDRO	MFT
23723	ESCAPE (2 X JGO)	CHAPA
23724 P	EMBRAGUE	PREMIUM
23725 P	CARTER	PREMIUM
23726 P	BOMBA ACEITE	PREMIUM
23727 P	ENCENDIDO	PREMIUM
23728 P	ALTERNADOR	PREMIUM
23729 P	C/T/ALTERNADOR	PREMIUM
12-7751	TAPA DE VÁLVULAS	NITRILO
9-615	KIT O´RING COMPLETO	NITRILO
8-615	KIT O´RING CABEZA CIL.	NITRILO

20092 P - Juego completo

21092 P - Cabeza de Cilindro

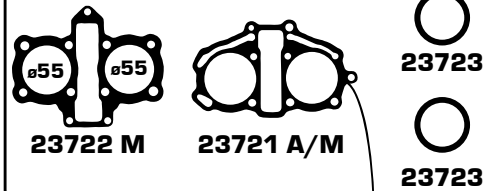

Bases de Cil. ALMA METAL
incluidas en las líneas
PREMIUM y PREMIUM C/O´RING

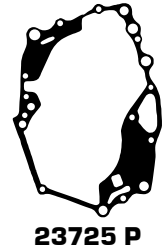
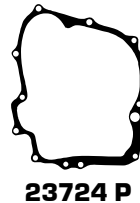

9-615 - Kit O´ring Completo

8-615 - Kit O´ring Cabeza Cil.

